

Owner's Manual

ABI Force Z-23

Self-Propelled, Zero-Turn, Multi-Task Vehicle

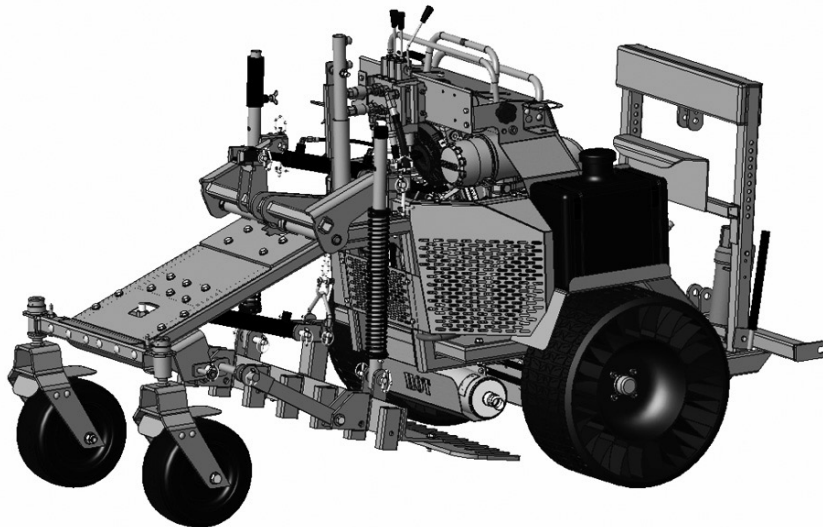

NOTE: This Owner's Manual covers several models. Features may vary by model. Not all features in this manual are applicable to all models and the model depicted may differ from yours.

For Your Records

Located underneath the knee pad on the right side of the frame is an ID plate showing the serial number. Record your machine's information and serial number in the space provided below. ABI will use this information to give you prompt, efficient service when you order parts or need product support.

Model and Serial Number

Model Number: _____
Serial Number: _____
Invoice Number: _____
Purchaser's Name: _____

Contact Information

ABI Attachments, Inc
520 S. Byrkit Ave.
Mishawaka, IN 46544

Customer Support

Email: abicustomerservice@abiattachments.com
Phone: 877-788-7253
Website: www.abisupport.com

Table of Content

Warranty.....	3
Safety.....	8
Uncrating & Setup.....	12
Controls & Operation.....	14
Attachment System.....	19
Maintenance.....	23
Service Schedule.....	32

Product Manual Information

NOTE: This operators manual covers several models, Features may vary by model. Not all features in this manual are applicable to all models depicted may differ from yours.

General Information

36 MONTH LIMITED WARRANTY

NOTE: *TERMS & CONDITIONS FOR 3-YEAR UNLIMITED HOURS RESIDENTIAL, COMMERCIAL, AND RENTAL KOHLER COMMAND PRO EFI ENGINE WARRANTY FOLLOW THE CHASSIS TERMS & CONDITIONS*

ABI FORCE Z23S CHASSIS & ATTACHMENTS TERMS & CONDITIONS

“ABI” means ABI Attachments, Inc. 520 S Byrkit Ave, Mishawaka, Indiana 46544, 877.788.7253. The ABI FORCE® is warranted for thirty-six (36) months, from the original consumer invoice date, against defects in materials and/or workmanship when put to normal and designed consumer or commercial use. However, rental usage is warranted for 24 months. This warranty is only valid on new equipment to the original purchaser with proof of purchase.

The warranty holder is responsible for performing reasonable and proper maintenance. The warranty holder is further responsible for performing replacement of normally wearing parts, including ground-engaging components of optional attachments at additional consumer expense. Attachments and options purchased and approved by ABI for use on the ABI Force® are also covered under this thirty-six (36) month term. ABI in no way warrants engines, hydraulic motors, hydraulic pumps, tires, or other trade accessories since these items are warranted separately by their respective manufacturers; however ABI will assist in the processing of these limited warranty claims. (Generally: Engine is limited 36-months, Hydraulic Motors and Pumps are limited 12-months, Optional Michelin Tweels are “life” of the original usable tread or limited 36-months)

ABI’s obligation and or liability, under this warranty, of any product defect or claim for injury or damages is limited to repair or replacement of the product, or payment of the reasonable cost of repair or replacement of the product, at ABI’s sole discretion. During the warranty period, warranty parts or replacement product will ship by a standard method at no charge to the warranty holder, in the United States & Canada only. Expedited shipping of warranty parts or replacement product is the responsibility of the warranty holder.

To secure warranty service the warranty holder must, (1) report the defect immediately to ABI customer service for warranty consideration within the applicable warranty term in writing and discontinue use of the product; (2) present photographic evidence of the warranty claim and valid proof of purchase; (3) return the product or part to ABI or independent service technician within 30 days of defect discovery or failure for return, inspection or repair, if required. If ABI is unable to repair the product to conform to the warranty after a reasonable number of attempts, ABI will provide, at its option, one of the following: (a) a replacement for the product or, (b) a full refund of the purchase price. Repair, replacement, or refunds are the warranty holder’s EXCLUSIVE remedies against ABI under this limited warranty.

ABI IS NOT RESPONSIBLE FOR THE FOLLOWING: (1) Equipment purchased used; (2) Any equipment that has been altered or modified in ways not approved by ABI, including, but not limited to, unauthorized repair, and acts of God; (3) Depreciation or damage caused by normal wear, damage due to inadequate maintenance, lack of reasonable and proper maintenance, failure to follow operating instructions/recommendations; misuse, abuse, lack of proper protection during storage or use, vandalism, the elements, freezing of any kind, collision or accident; (4) Normal maintenance/wear parts and/or service, including but not limited to cables, chains, switches, pins, bolts, tires, rims, bearings, and ground-engaging components. Periodic replacement of normally wearing parts and ground-engaging components of chassis and options are the responsibility of the warranty holder.

To the extent permitted by law, **the limited warranty stated above is the exclusive warranty given by ABI, to the original purchaser, and ABI disclaims any other warranties. There are no other warranties, either expressed or implied, including any warranty of merchantability, fitness for a particular purpose, or arising from a course of dealing or trade usage. ABI shall not be liable in any event for incidental or consequential or other special damages under any theory of strict liability or negligence, or expenses of any kind, including, but not limited to, personal injury, damage to property, cost of equipment rentals, loss of profit, or cost of hiring services to perform tasks normally performed by these products.** ABI reserves the right to make improvements in design or changes in specifications at any time, without incurring any obligation to owners of units previously sold.

Some jurisdictions do not allow limitations on how long an implied warranty lasts or the exclusion or limitation of incidental or consequential damages so the above limitations and exclusions may not apply to you. This warranty gives you specific legal rights, and you may also have other rights, which vary from jurisdiction to jurisdiction.

Owner Responsibilities:

You must maintain your ABI Product by following the maintenance procedures described in the Operator's Manual. Such routine maintenance, whether performed by a dealer or by you, is at your expense. Parts scheduled for replacement as required maintenance ("Maintenance Parts"), are warranted for the period of time up to the scheduled replacement time for that part. Failure to perform required maintenance and adjustments can be grounds for disallowing a warranty claim.

Items & Conditions Not Covered:

Not all product failures or malfunctions that occur during the warranty period are defects in materials or workmanship. This warranty does not cover the following:

- Product failures which result from the use of non-ABI approved replacement parts, or from installation and use of add-on, or modified non-ABI approved branded accessories and products.
- Product failures which result from failure to perform recommended maintenance and/or adjustments. Failure to properly maintain your ABI product per the Recommended Maintenance listed in the Operator's Manual can result in claims for warranty being denied.
- Product failures which result from operating the Product in an abusive, negligent, or reckless manner.
- Pickup and delivery charges unless otherwise specified
- Parts subject to consumption through use unless found to be defective. Examples of parts which are consumed, or used up, during normal Product operation include, but are not limited to, bearings (sealed or greasable), spark plugs, caster wheels and bearings, tires, filters, mats, pins, tips, shanks, and ground-engaging components.
- Failures caused by outside influence. Conditions considered to be outside influence included, but are not limited to: weather, storage practices, contamination, use of unapproved fuels, coolants, lubricants, additives, fertilizers, water, or chemicals, etc.
- Failure or performance issues due to the use of fuels (e.g. gasoline, diesel, or biodiesel) that do not conform to their respective industry standards.
- Normal noise, vibration, wear and tear, and deterioration. Normal "wear and tear" includes, but is not limited to: damage to pads due to wear or abrasion, worn painted surfaces, scratched decals, etc.

No Dealer Warranty:

The selling dealer makes no warranty of its own and the dealer has no authority to make any representation or promise on behalf of ABI, or to modify the terms or limitations of this warranty in any way.

Publish Date: 8/19/2019

LIMITED WARRANTY, COMMAND PRO EFI ENGINE

Kohler Co. warrants to the original retail consumer that each new engine will be free from manufacturing defects in materials or workmanship for the applicable coverage period as set forth below, beginning on date of purchase; provided the engine is operated and maintained in accordance with Kohler Co.'s instructions and manuals.

Type of use:

- Residential 3 Years - Unlimited Hours
- Commercial/Rental 3 Years - Unlimited Hours

Our obligation under this warranty is expressly limited, at our option, to the replacement or repair of such part or parts as inspection shall disclose to be defective at Kohler Co., Kohler, Wisconsin 53044, or at a service facility designated by Kohler Co.

EXCLUSIONS:

Mufflers on engines used commercially (non-residential) are warranted for one (1) year from date of purchase, except catalytic mufflers, which are warranted for two (2) years.

The following items are not covered by this warranty:

- Damage caused as a result of an accident or casualty.
- Failures caused by faulty repairs made by others.
- Failures caused by use of non-Kohler replacement service parts.
- Transportation charges in connection with the repair or replacement of defective parts.
- Repairs caused from improper storage, old or contaminated fuel left within the fuel system (tanks, fuel lines or carburetor).
- Damage caused from unreasonable use or neglect, normal wear, or premature wear from improper maintenance.
- Engine accessories such as fuel tanks, clutches, transmissions, power drive assemblies, and batteries, unless supplied or installed by Kohler Co. These are subject to the warranties, if any, of their manufacturers.

IMPLIED OR STATUTORY WARRANTIES, INCLUDING WARRANTIES OF MERCHANTABILITY OR FITNESS FOR A PARTICULAR PURPOSE, ARE EXPRESSLY LIMITED TO THE DURATION OF THIS WRITTEN WARRANTY. WE MAKE NO OTHER EXPRESS WARRANTY, OR IS ANYONE AUTHORIZED TO MAKE ANY ON OUR BEHALF. KOHLER CO. AND/OR THE SELLER SHALL NOT BE LIABLE FOR SPECIAL, INDIRECT, INCIDENTAL, OR CONSEQUENTIAL DAMAGES OF ANY KIND.

Some states or countries do not allow limitations on how long an implied warranty lasts, or the exclusion or limitation of incidental or consequential damages, so the above limitation or exclusion may not apply to you. This warranty gives you specific legal rights, and you may also have other rights which vary from country to country, or state to state within U.S.A.

TO OBTAIN WARRANTY SERVICE:

Original retail consumer must bring the engine to an authorized Kohler dealer found by visiting www.KohlerEngines.com or telephone 1-800-544-2444 (U.S.A. and Canada).

Warranty Conditions-Australia:

The benefits given to you under this warranty are in addition to other rights and remedies that you have under Australian law in relation to the goods. All costs associated with claiming under this warranty must be borne by the consumer, including transport costs incurred in the repair or replacement of any defective part. Our goods come with guarantees that cannot be excluded under the Australian Consumer Law. You are entitled to a replacement or refund for a major failure and for compensation for any other reasonably foreseeable loss or damage. You are also entitled to have the goods repaired or replaced if the goods fail to be of acceptable quality and the failure does not amount to a major failure.

Kohler Co. Service Agent in Australia: EPG Engines
31 Powers Road
Seven Hills, NSW, 2147
61 2 9830 2295
61 1800 069 399
www.epgengines.com.au
ENGINE DIVISION, Kohler Co., Kohler Wisconsin

B) CALIFORNIA AND FEDERAL EXHAUST AND EVAPORATIVE EMISSIONS CONTROL WARRANTY STATEMENT YOUR WARRANTY RIGHTS AND OBLIGATIONS

The California Air Resources Board, US Environmental Protection Agency ("US EPA") and Kohler Co. are pleased to explain the exhaust and evaporative emissions control systems warranty on your 2018-2020 Small Off-Road Engine ("SORE") and engine powered equipment as applicable. In California and the USA, new equipment that use SORE must be designed, built and equipped to meet California and US EPA stringent anti-smog standards. Kohler Co. must warrant the emission control systems on your SORE and engine powered equipment for the period listed below provided there has been no abuse, neglect or improper maintenance of your SORE or engine powered equipment leading to the failure of the emission control systems.

Your exhaust emission control systems may include parts such as carburetors, fuel-injection systems, the ignition system, and catalytic converters. Also included may be an evaporative emission control system which may include parts such as fuel tanks, fuel lines (for liquid fuel and vapors), fuel caps, valves, carbon canisters, clamps, connectors, and other associated components.

MANUFACTURER'S WARRANTY COVERAGE:

The 1995 and later SORE exhaust and evaporative emission control systems are warranted for three years. If any exhaust or evaporative emission-related part on your SORE or engine powered equipment is defective, the part will be repaired or replaced by Kohler Co.

OWNER'S WARRANTY RESPONSIBILITIES:

As the SORE or engine powered equipment owner, you are responsible for the performance of the required maintenance listed in your owner's manual. Kohler Co. recommends that you retain all receipts covering maintenance on your SORE or engine powered equipment, but Kohler Co. cannot deny warranty coverage solely for the lack of receipts. As the SORE or engine powered equipment owner, you should however be aware that Kohler Co. may deny you warranty coverage if your SORE or engine powered equipment or a part has failed due to abuse, neglect, improper maintenance or unapproved modifications.

You are responsible for presenting your SORE or engine powered equipment to a Kohler Co. distribution or service center as soon as a problem exists. The warranty repairs should be completed in a reasonable amount of time, not to exceed 30 days. If you have a question regarding your warranty coverage, you should contact a Kohler Dealer at 1-800-544-2444 or visit www.kohlerengines.com.

GENERAL EMISSIONS WARRANTY COVERAGE:

The warranty period begins on the date the engine or equipment is delivered to an ultimate purchaser. Kohler Co. warrants to the ultimate purchaser and each subsequent purchaser that the engine is: Designed, built, and equipped so as to conform with all applicable regulations adopted by the Air Resources Board and US EPA; and free from defects in materials and workmanship that cause the failure of a warranted part to be identical in all material respects to the part as described in the engine manufacturer's application for certification for the warranty period stated above.

The warranty on emissions-related parts is as follows:

- (1) Any warranted part that is not scheduled for replacement as required maintenance in the owner's manual supplied, is warranted for the warranty period stated above. If any such part fails during the period of warranty coverage, the part will be repaired or replaced by Kohler Co. at no charge to the owner. Any such part repaired or replaced under the warranty will be warranted for the remaining warranty period.
- (2) Any warranted part that is scheduled only for regular inspection in the owner's manual supplied, is warranted for the warranty period stated above. Any such part repaired or replaced under warranty will be warranted for the remaining warranty period.
- (3) Any warranted part that is scheduled for replacement as required maintenance in the owner's manual supplied, is warranted for the period of time prior to the first scheduled replacement point for that part. If the part fails prior to the first scheduled replacement, the part will be repaired or replaced by Kohler Co. at no charge to the owner. Any such part repaired or replaced under warranty will be warranted for the remainder of the period prior to the first scheduled replacement point for the part.
- (4) Add-on or modified parts that are not exempted by the Air Resources Board may not be used. The use of any non-exempted add-on or modified parts by the ultimate purchaser will be grounds for disallowing a warranty claim. The manufacturer will not be liable to warrant failures of warranted parts caused by the use of a non-exempted add-on or modified part.

PARTS COVERED BY WARRANTY:

Listed below are the parts (if equipped) covered by the Federal and California Emission Control Systems Warranty. Some parts listed below may require scheduled maintenance and are warranted up to the first scheduled replacement point for that part.

PARTS COVERED BY WARRANTY:

Listed below are the parts (if equipped) covered by the Federal and California Emission Control Systems Warranty. Some parts listed below may require scheduled maintenance and are warranted up to the first scheduled replacement point for that part.

- Oxygen sensor
- Intake manifold
- Exhaust manifold
- Catalytic muffler
- Thermal reactor muffler
- Spark advance module
- Crankcase breather
- Air Injection System
 - Air pump or pulse valve assembly
 - Control/distribution valve
 - Distribution manifold
 - Air hoses
 - Vacuum lines
- Ignition module(s) with high tension lead
- Gaseous fuel regulator
- Electronic control unit
- Carburetor or fuel injection system
- Fuel metering valve
- Air filter, fuel filter, and spark plugs (only to first scheduled replacement point)
- Evaporative System
 - Carbon canister and carbon canister mounting bracket
 - Carbon canister filter
 - Purge port/orifice connector
 - Fuel tank
 - Fuel cap and fuel cap gasket
 - Primer bulb canister
 - Fuel line (for liquid fuel and fuel vapors), fuel line fittings and clamps -Carburetor purge port connector

Limitations:

This Emission Control Systems Warranty shall not cover any of the following:

- a. Consequential damages such as loss of time, inconvenience, loss of use of the engine or equipment, etc.
- b. Diagnosis and inspection fees that do not result in eligible warranty service being performed.

C) CALIFORNIA AND FEDERAL EXHAUST EMISSION CONTROL WARRANTY STATEMENT YOUR WARRANTY RIGHTS AND OBLIGATIONS

The California Air Resources Board, US Environmental Protection Agency ("US EPA") and Kohler Co. are pleased to explain the exhaust emission control systems warranty on your 2018-2020 Off-Road Large Spark-Ignition engine displacing less than 1 liter ("LSI <1L") and engine powered equipment as applicable. In California and the USA, LSI <1L must be designed, built and equipped to meet California and US EPA stringent anti-smog standards. Kohler Co. must warrant the emission control systems on your LSI <1L for the period listed below provided there has been no abuse, neglect or improper maintenance of your LSI <1L.

Your exhaust emission control systems may include parts such as carburetors, fuel-injection systems, the ignition system, and catalytic converters.

MANUFACTURER'S WARRANTY COVERAGE:

The 1995 and later LSI <1L exhaust emission control system is warranted for three years. If any exhaust emission-related part on your LSI <1L is defective, the part will be repaired or replaced by Kohler Co.

OWNER'S WARRANTY RESPONSIBILITIES:

As the LSI <1L owner, you are responsible for the performance of the required maintenance listed in your owner's manual. Kohler Co. recommends that you retain all receipts covering maintenance on your LSI <1L, but Kohler Co. cannot deny warranty solely for the lack of receipts. As the LSI <1L owner, you should however be aware that Kohler Co. may deny you warranty coverage if your LSI <1L or a part has failed due to abuse, neglect, improper maintenance or unapproved modifications.

You are responsible for presenting your LSI <1L to a Kohler Co. distribution or service center as soon as a problem exists. The warranty repairs should be completed in a reasonable amount of time, not to exceed 30 days. If you have a question regarding your warranty coverage, you should contact Kohler Dealer at 1-800-544-2444 or visit www.KohlerEngines.com.

GENERAL EMISSIONS WARRANTY COVERAGE:

The warranty period begins on the date the engine or equipment is delivered to an ultimate purchaser. Kohler Co. warrants to the ultimate purchaser and each subsequent purchaser that the engine is:

Designed, built, and equipped so as to conform with all applicable regulations adopted by the Air Resources Board and US EPA; and Free from defects in materials and workmanship that cause the failure of a warranted part to be identical in all material respects to the part as described in the engine manufacturer's application for certification.

PARTS COVERED BY WARRANTY:

1. Any warranted part that is not scheduled for replacement as required maintenance in the owner's manual supplied, is warranted for the warranty period stated above. If any such part fails during the period of warranty coverage, the part will be repaired or replaced by Kohler Co. at no charge to the owner. Any such part repaired or replaced under the warranty will be warranted for the remaining warranty period.
2. Any warranted part that is scheduled only for regular inspection in the owner's manual supplied, is warranted for the warranty period stated above. Any such part repaired or replaced under warranty will be warranted for the remaining warranty period.
3. Any warranted part that is scheduled for replacement as required maintenance in the owner's manual supplied, is warranted for the period of time prior to the first scheduled replacement point for that part. If the part fails prior to the first scheduled replacement, the part will be repaired or replaced by Kohler Co. at no charge to the owner. Any such part repaired or replaced under warranty will be warranted for the remainder of the period prior to the first scheduled replacement point for the part.
4. Add-on or modified parts that are not exempted by the Air Resources Board may not be used. The use of any non-exempted add-on or modified parts by the ultimate purchaser will be grounds for disallowing a warranty claim. The manufacturer will not be liable to warrant failures of warranted parts caused by the use of a non-exempted add-on or modified part.

PARTS COVERED BY WARRANTY:

Listed below are the parts (if equipped) covered by the Federal and California Emission Control Systems Warranty. Some parts listed below may require scheduled maintenance and are warranted up to the first scheduled replacement point for that part.

- Oxygen sensor
- Intake manifold
- Exhaust manifold
- Catalytic muffler
- Thermal reactor muffler
- Fuel line, fuel line fittings and clamps Spark advance module
- Crankcase breather
- Air Injection System
 - Air pump or pulse valve assembly
 - Control/distribution valve -Distribution manifold
 - Air hoses
 - Vacuum lines
- Ignition module(s) with high tension lead
- Gaseous fuel regulator
- Electronic control unit
- Carburetor or fuel injection system
- Fuel metering valve
- Air filter, fuel filter, and spark plugs (only to first scheduled replacement point)

Limitations

This Emission Control Systems Warranty shall not cover any of the following:

- a. Consequential damages such as loss of time, inconvenience, loss of use of the engine or equipment, etc.
- b. Diagnosis and inspection fees that do not result in eligible warranty service being performed.

Safety



WARNING! This symbol points out important safety instructions which, if not followed, could endanger the personal safety and/or property of yourself and others. Read and follow all instructions in this manual before attempting to operate this machine. Failure to comply with these instructions may result in personal injury. When you see this symbol, HEED ITS WARNING!

CALIFORNIA PROPOSITION 65



WARNING! Engine Exhaust, some of its constituents, and certain vehicle components contain or emit chemicals known to the State of California to cause cancer and birth defects or other reproductive harm.



WARNING! Battery posts, terminals, and related accessories contain lead and lead compounds, chemicals known to the State of California to cause cancer and reproductive harm. Wash hands after handling.



WARNING! This machine is equipped with an internal combustion engine and should not be used on or near any unimproved forest-covered, brush-covered or grass-covered land unless the engine's exhaust system is equipped with a spark arrestor meeting applicable local or state laws (if any). If a spark arrestor is used, it should be maintained in effective working order by the operator. In the state of California the above is required by law (Section 4442 of the California Public Resources Code). Other states may have similar laws. Federal laws apply on federal lands. A spark arrestor for the muffler is available through your nearest engine authorized service dealer or contact the service department, 520 S. Byrkit Ave. Mishawaka, IN 46544.



DANGER! The engine manufacturer has supplied an engine owner's manual for information regarding US Environmental Protection Agency (EPA) and California Air resources Board (CARB) regulations relating to emission control systems, maintenance, and warranty. Making any unauthorized alterations or modifications to the engine, fuel, or venting systems may violate EPA and/or CARB regulations. Further information may be obtained from the engine manufacturer.



DANGER! This machine was built to be operated according to the safe operation practices in this manual. As with any type of power equipment, carelessness or error on the part of the operator can result in serious injury. This machine is capable of amputating hands and feet and throwing objects. Failure to observe the following safety instructions could result in serious injury or death.

Operational Safety Rules

Please exercise caution at all times when setting up, operating, or performing maintenance on the ABI Force. Remember, any piece of equipment like the ABI Force can cause injury if operated improperly or if the user does not understand how to operate the equipment.

Training

- Read the operator's manual and other training material carefully. Be familiar with the controls, safety signs, and the proper use of the equipment.
- If the operator or mechanic can not read the language of this manual it is the owner's responsibility to explain this material to them.
- Never allow children or people unfamiliar with these instructions to use or service the machine. Local regulations may restrict the age of the operator.
- Never use while people, especially children, or pets are nearby.
- Keep in mind that the operator or user is responsible for accidents or hazards occurring to other people or their property.
- Do not carry passengers.
- All drivers and mechanics should seek and obtain professional and practical instruction. The owner is responsible for training the users.
- Such instruction should emphasize:
 - The need for care and concentration when working with ride-on machines;
 - Control of a ride-on machine sliding on a slope will not be regained by the application of the brake.
- Main Reasons for loss of control:
 - Insufficient wheel grip
 - Being driven too fast;
 - Inadequate braking
 - The type of machine is unsuitable for its task
 - Lack of awareness of the effect of ground conditions, especially slopes.
 - Incorrect hitching and load distribution.
- The owner/user can prevent and is responsible for accidents or injuries occurring themselves, other people, or property.
- Read the operator's manual and other training material carefully. Be familiar with the controls, safety signs, and the proper use of the equipment.
- Operate only in daylight or in good artificial light.
- Before attempting to start the engine, disengage all implements, shift into neutral, and engage the parking brake.
- Do not put hands or feet near or under rotating parts.
- Using the machine demands attention. To prevent tipping or loss of control:
 - Watch for holes or other hidden hazards.
 - Use caution when operating the machine on a steep slope. Reduce your speed when making sharp turns or when turning on hillsides.
 - Avoid sudden stops and starts. Do not go from reverse to full forward without first coming to a complete stop.
 - Before backing up, look to the rear and ensure that no one is behind the machine.
 - Watch out for traffic when near of crossing roads. Always yield the right of way.
- Stay alert for holes in the terrain and other hidden hazards.
- Use care when pulling loads or using heavy equipment.
 - Use only approved hitch points
 - Limit loads to those you can safely control
 - Do not turn sharply
 - Use care when reversing
- Watch out for traffic when crossing or near roadways.
- Never operate the machine with damaged guards, shields, or without safety protective devices in place. Be sure all interlocks are attached, adjusted properly, and functioning properly.
- Do not change the engine governor settings or overspeed the engine. Operating the engine at excessive speed may increase the hazard of personal injury.

Operation



Engine exhaust contains carbon monoxide, which is an odorless, deadly poison that can kill you.

Do not run engine indoors or in an enclosed area.

- Do not operate the engine in a confined space where dangerous carbon monoxide fumes can collect.
- Before leaving the operator's position:
 - Stop on level ground
 - Lower the attachments
 - Set the parking brake
 - Stop the engine and remove the key
- Disengage drive to attachments when transporting or not in use.

- Stop the engine and disengage drive to attachment:
 - Before refueling;
 - Before checking, cleaning or working on the machine;
 - After striking a foreign object or if an abnormal vibration occurs. Inspect the machine for damage and make repairs before restarting and operating the equipment.
- Turn the fuel off at the conclusion of operation. Reduce the throttle setting during engine run-out and, if the engine is provided with a shut-off valve.
- Look behind and down before backing up to be sure of a clear path.
- Slow down and use caution when making turns and crossing roads and sidewalks.
- Do not operate the machine under the influence of alcohol or drugs.
- Use care when loading or unloading the machine into a trailer or truck.
- Use care when approaching blind corners, shrubs, trees, or other objects that may obscure vision.
- Carefully release pressure from components with stored energy. This can be done by moving hydraulic controls with the machine off.
- Use jack stands to support components when required.
- Disconnect battery and remove spark plug wire before making any repairs. Disconnect the negative terminal first and the positive last. Reconnect positive first and negative last.
- Keep hands and feet away from moving parts. If possible, do not make adjustments with the engine running. If the engine must be running to perform a maintenance adjustment, keep hands, feet, clothing, and any parts of the body away from the attachments and any moving parts, especially the screen at the side of the engine.
- Charge batteries in an open well ventilated area, away from spark and flames. Unplug charger before connecting or disconnecting from battery. Wear protective clothing and use insulated tools.
- Before applying pressure to the system make sure all hydraulic line connectors are tight and all hydraulic hoses and lines are in good condition

Maintenance & Storage

- Keep all nuts, bolts and screws tight to be sure the equipment is in safe working condition.
 - Never store the equipment with fuel in the tank inside a building where fumes may reach an open flame or spark.
 - Allow the engine to cool before storing in any enclosure.
 - To reduce the fire hazard, keep the engine, muffler, battery compartment and fuel storage area free of grass, leaves, or excessive grease.
 - Keep all parts in good working condition and all hardware and hydraulic fittings tightened. Replace all worn or damaged parts and decals.
 - If the fuel tank has to be drained, do this outdoors.
 - Be careful during adjustment of the machine to prevent entrapment of the fingers between moving parts and fixed parts of the machine.
 - Stop engine and remove key. Wait for all movement to stop before adjusting, cleaning or repairing. Disengage drives, lower the implement, set parking brake.
 - Keep your body and hands away from pin hole leaks or nozzles that eject hydraulic fluid under high pressure. Use paper or cardboard, not your hands, to search for leaks. Hydraulic fluid escaping under pressure can have sufficient force to penetrate the skin and cause serious injury. Seek immediate medical attention if fluid is injected into skin.
 - Before disconnecting or performing any work on the hydraulic system, all pressure in the system must be relieved by stopping the engine and lowering the attachments to the ground.
 - Use caution when using the ABI Force as a tow vehicle. Do not exceed 750 lbs towed by the ABI Force.
 - Only use authorized attachments on the ABI Force. Unauthorized attachments or modifications may void the warranty.
 - Check all fuel lines for tightness and wear on a regular basis. Tighten or repair them as needed.
-

Safety Guards & Covers

Safety is a primary concern in the design and manufacturing of all ABI Attachments, Inc. products. Our extensive efforts to provide safe equipment can be negated by a single careless act by the operator. In addition to the design and configuration of the ABI Force, hazard control and accidents are also dependent upon the awareness and knowledge of the operator, along with proper maintenance of the ABI Force. The best safety device is an informed and careful operator.

Safety guards are mounted around the engine and in front of the operator. These guards are designed to protect the operator, along with the ABI Force. Removing these guards could cause injury to an operator and could void the ABI Force warranty. Remove these guards ONLY when the unit is turned off, the parking brake is applied, and all attachments are resting on the ground.



WARNING! Hydraulics may move even without engine running.

- Never perform maintenance on the ABI Force when children are present.
- Never allow anyone near the operation controls while performing service or maintenance to the ABI Force.
- Keep the engine area of the ABI Force free of accumulate debris, fuel, or excess grease and oil build up to prevent fire hazard.
- Periodically check all hardware on the ABI Force. Ensure that all hardware is present and tight to ensure the ABI Force is in safe operating condition. Replace any damaged or missing hardware prior to operating the ABI Force.
- Never perform maintenance on the ABI Force while parking brake is disengaged.

Hydraulic Devices & Systems

Hydraulic fluid escaping under pressure may have sufficient force to penetrate skin and cause serious injury. If foreign fluid is injected into the skin or eyes, seek immediate medical attention.



WARNING! Keep body and hands away from pinholes or nozzles that could inject hydraulic fluid under high pressure. Use paper or cardboard, not your hands, to search for leaks! Wear gloves and safety glasses.

Safely relieve all pressure in the system before performing any work on the system, and make sure that:

- The ignition switch is OFF
- The key is removed
- The engine spark plug wires are removed
- All connections to the negative terminal of the battery are removed
- The parking brake is set
- All bypass valves, if so equipped, are open
- Hydraulic controls are actuated to release pressure on pumps, cylinders, etc. If “float” positions are available, they should be used.

After the above operations are completed, it should be safe to begin disconnecting the lines or components. It is still a good idea to cover the connection with a cloth shield and then gently loosen connections.



WARNING! Make sure all hydraulic fluid connections are tight and all hydraulic hoses and lines are in good condition before applying pressure to the system.

Storage Safety Rules

- Never store the ABI Force in an area accessible by children. Always remove the keys before storage.
- Never store the ABI Force with fuel inside the tank inside a building where fumes could reach an open flame or spark.
- Allow the ABI Force engine to cool before storing in an enclosed area.
- Lubricate all moving parts of the ABI Force to prevent rust during long periods of storage.
- Before storing remove all accumulated debris from the ABI Force and all attachments.

Note: Throughout this manual, Left and Right, front and back are determined by someone in the operators position.

Uncrating & Setup

Tools Needed

- Safety glasses and gloves
- Tin snips to cut metal banding
- Hammer/Pry Bar/Knife for packaging removal
- ½" and ¾" Wrench and/or socket for rake attachment

Removing from Shipping Crate

1. Remove any banding from around the Force. Set aside any additional attachments packaged with it. Be careful not to discard any attachments that are individually mixed with bands or packaging.
2. Remove all of the outside supports from around the shipping crate.
3. Before starting the ABI Force make sure to check the engine oil and hydraulic system levels on the unit. The engine oil dipstick is located inside the knee pad of the ABI Force. Refer to **Figure 1** for reference or see to the maintenance section of the Kohler Engine Manual for information. Engines are factory filled with SAE 30w oil to facilitate break in during the first 25 hours of operation.

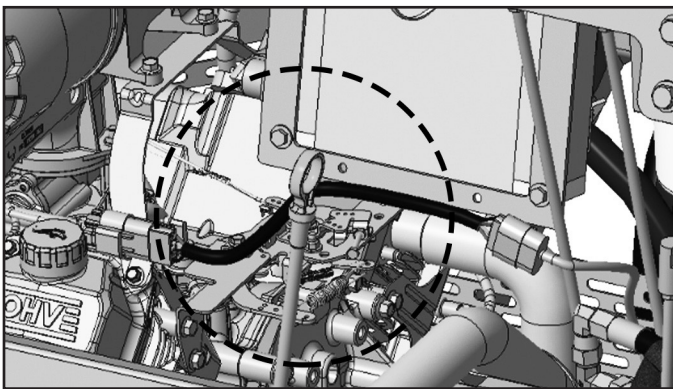

Figure 1: Oil dipstick location

4. To check the hydraulic fluid use the hydraulic reservoir located on the back right side of the Force. The level should fall between the min and max lines of the transparent reservoir. Use SAE 5w-40 motor oil such as Mobil DELVAC 1 ESP (Diesel Engine Oil). Refer to **Figure 2** for reference.

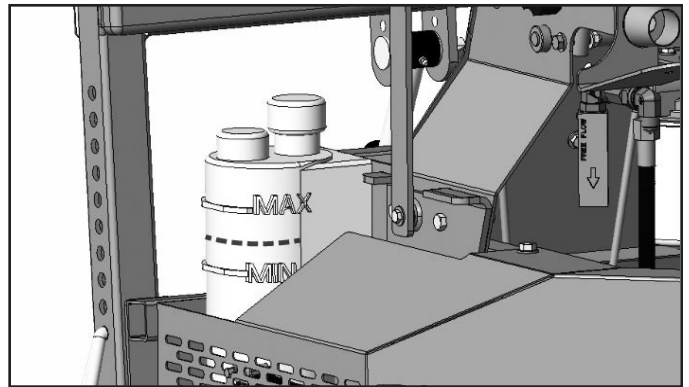

Figure 2: Hydraulic oil reservoir location

Note to the operator: Always check fluid levels on a flat surface to ensure the level of the oil is properly read. ABI ships the ABI Force with oil pre-filled.

5. Next, locate the fuel tank on the right side of the ABI Force. The unit does not ship with fuel in the tank, so fuel will need to be added prior to starting. Use clean, fresh regular unleaded gasoline with 87 octane or higher. **Never use gasoline containing methanol or gasoline containing more than 10% ethanol because the fuel system may be damaged.**

6. Using the key sent with the ABI Force start the unit. Once the unit has run for about 30-60 seconds throttle back the unit some before further operation.

Note to the operator: Do not attempt to drive the force until completing steps 7-9; Further steps are required AFTER starting the force AND BEFORE moving the unit to ensure the ABI Force or attachments are not damaged while dismantling the shipping crate.

7. With the ABI Force started, use the bent hydraulic control lever to raise the mid-mount attachment system clear of the shipping crate. The bent hydraulic control lever will be the lever furthest to the left in the hydraulic lever set. Refer to **Figure 3** for reference.

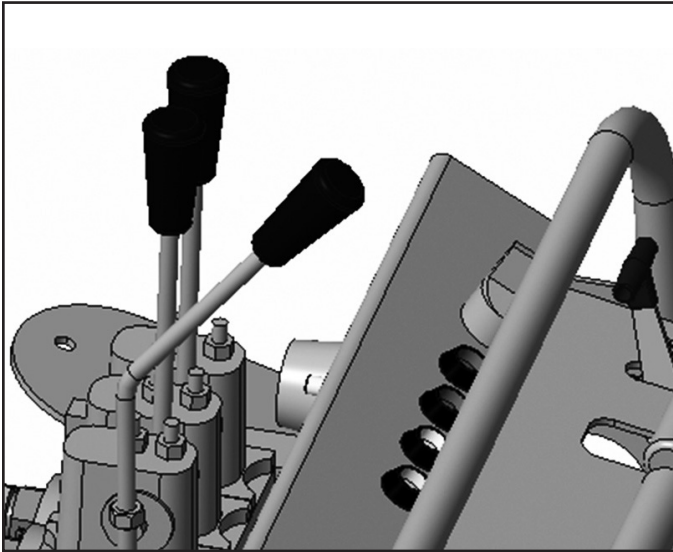

Figure 3: Bent Handle Raises Mid-mount System

8. The parking brake lever can be located on the right side of the ABI Force connected to the dash. Push the lever forward and down to disengage the parking brake. Refer to **Figure 4** for reference.

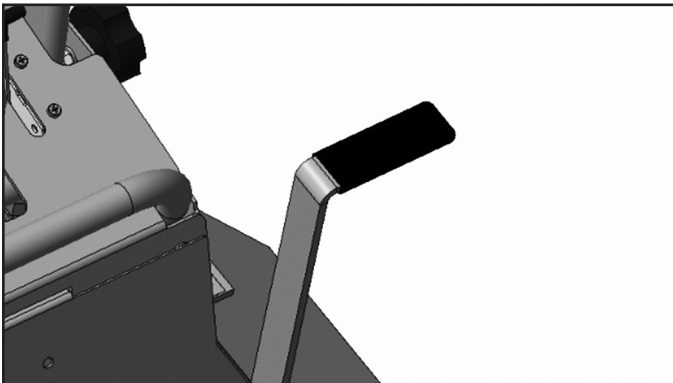

Figure 4: Park brake location

9. Using the grip controls, slowly & simultaneously pull both controls back slowly and together to back the ABI Force off the shipping crate. Ensure that there are no obstacles or people behind and that the mid-mount attachment system fully clear. It may be beneficial to use the crating material as a ramp to ease the unit off the skid. Watch out for nails or screws. Use **Figure 5** for reference.

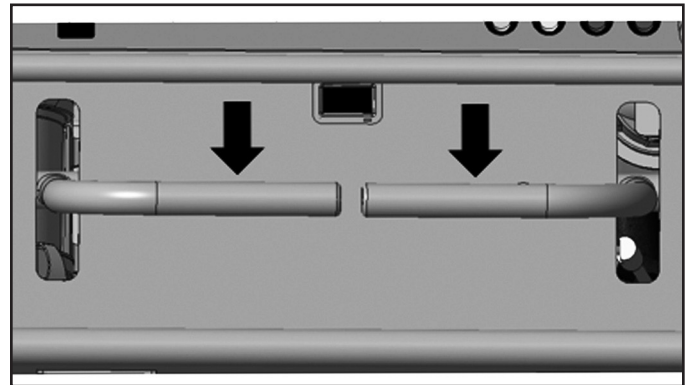

Figure 5: Pull back for reverse

10. With the ABI Force clear of the shipping crate, you are ready to begin adding attachments.

For setup assistance contact ABI's Customer Service department. Contact information can be found in the "Contact Us" section of this manual on page 2.

Rake Installation

1. If installing optional Edger system, install per instructions in Edger kit. Hardware in manual canister will not be used.
2. If not installing Edger Remove hardware holding end rake sections on Mid-mount attachment system with $\frac{1}{2}$ " wrench and discard.
3. Flip Rake sections over to extend outward and install hardware with $\frac{3}{4}$ " wrenches. Hardware is provided in the manual canister on the backrest. See **Figure 6** for finished installation.

Controls and Operation

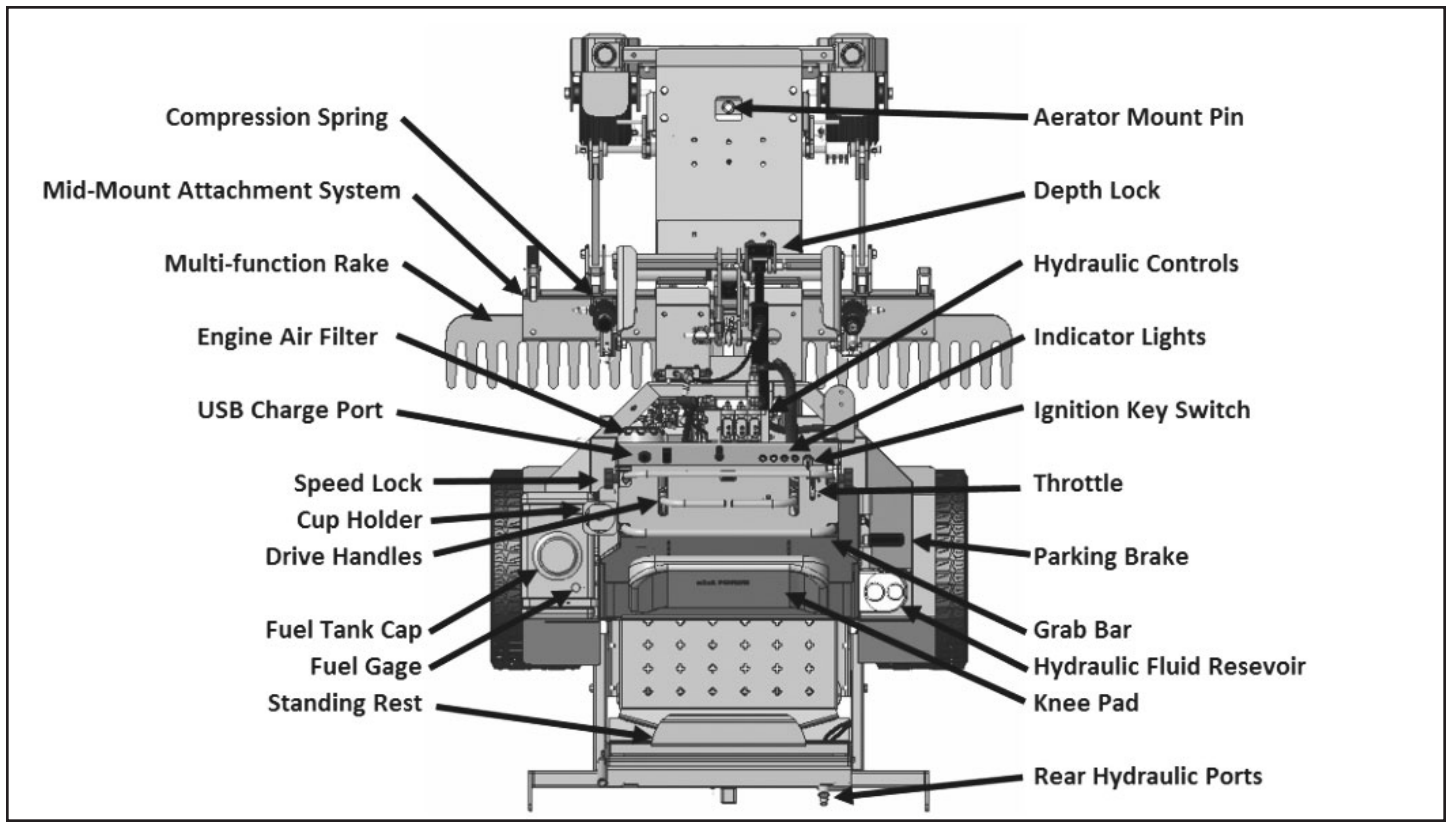

Figure 6: Control layout

Parking Brake Control- To engage, pull up and toward the operator it engages. To disengage, push forward and down it releases.



ALWAYS SET PARK BRAKE WHEN TRAILERING UNIT.

Note: If the drive control levers are engaged while the park brake is set brake damage may result.



Reverse Handle/ Grab Bar- Used to help the operator enter and exit the unit. Also used to help operator go in reverse when using the Drive Handles.

Throttle Control Handle- Used for increasing and decreasing the speed of the engine. Full speed, above 3000 RPM, is recommended for all operations.



Speed-Lock System

Setting the Speed-Lock:

The Speed-lock is used to limit the top speed of the ABI Force.

1. With the engine off and the park brake set, loosen the black plastic knobs located on the side of the control panel. Use Figure 7 for reference.
2. Pull the Speed-Lock bar back until it contacts the control lever moved to the desired stroke and tighten both black plastic knobs back down. Use the indicated settings for consistency.
3. Test to make sure the speed of the ABI Force is appropriate for the desired application. If the speed is set too slow/fast repeat steps 2 until the proper speed is obtained.

Note: The following are operational suggestions.

Level 4 – Transport, not operating attachments.

Level 3 – Higher speed operations such as grooming or loosening.

Level 2 and 1 – Finer work such a laser grading, a new operator learning.

Note: It's highly suggested that new operators be given a training session with the ABI Force Speed-Lock set to 2 or 1 to allow them time to become familiar with the machine.

Note: Speed-Lock limits forward travel speed, but does not affect reverse speeds. Always use caution when going in reverse.

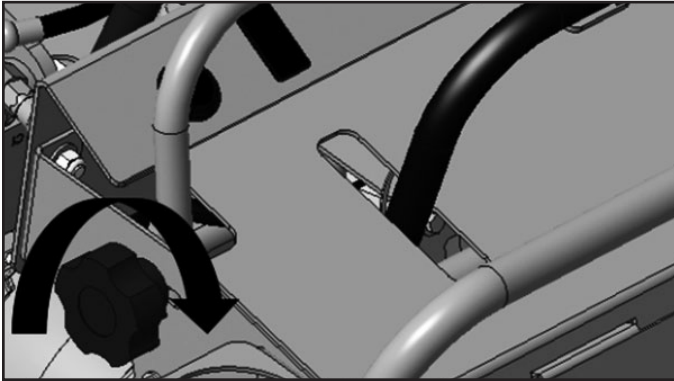
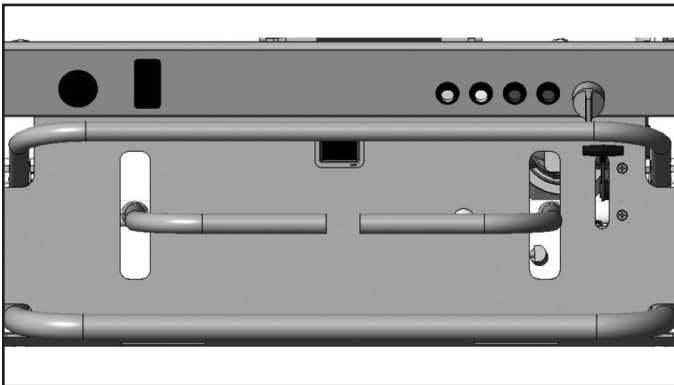

Figure 7: Shows tightening Speed-Lock

Drive Handles- Control traction drive. Forward/Backwards/ Left/Right.



WARNING! Make all control changes gradual. Sharp rapid movements of controls can lead to turf defacement and loss of control.



NEUTRAL POSITION



WARNING! The ABI Force is a commercial piece of equipment and does not have an engine kill switch in the operator platform. The unit will move if the control handles are engaged. Always set the park brake and turn off the engine before dismounting the machine.

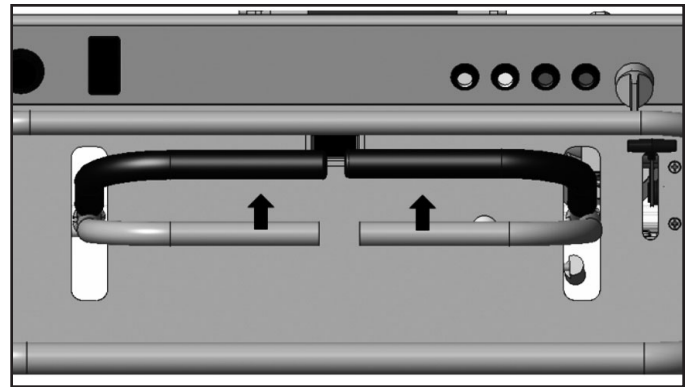

DRIVING FORWARD

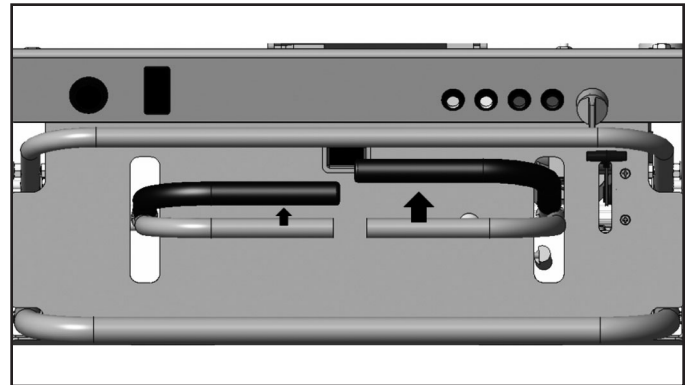

TURNING LEFT WHILE DRIVING FORWARD

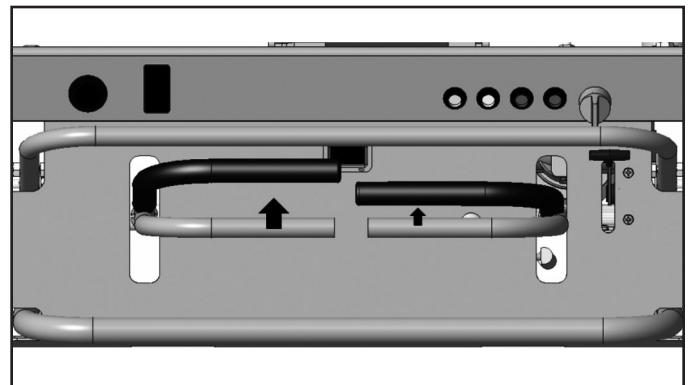

TURNING RIGHT WHILE DRIVING FORWARD

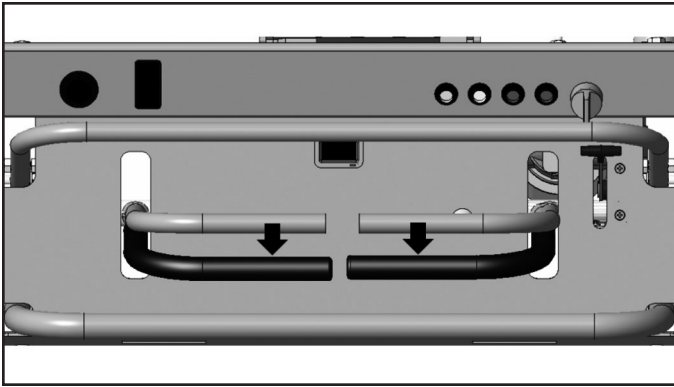

DRIVING BACKWARDS

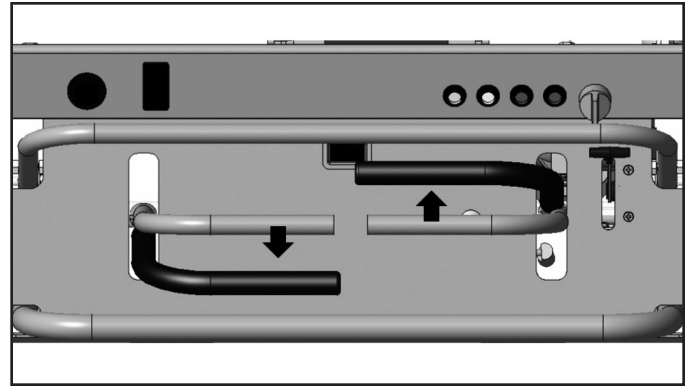

COUNTER-CLOCKWISE ZERO TURN

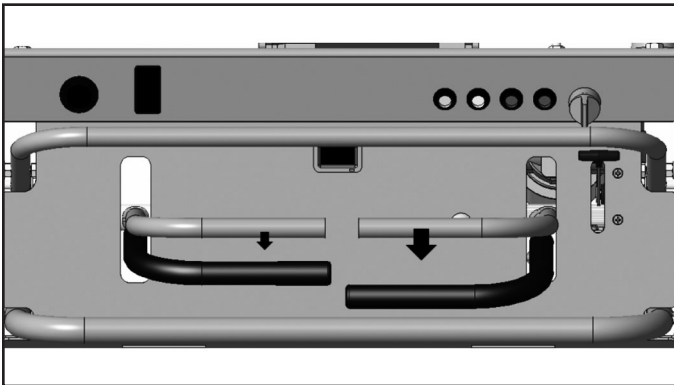

BACKING TO THE LEFT

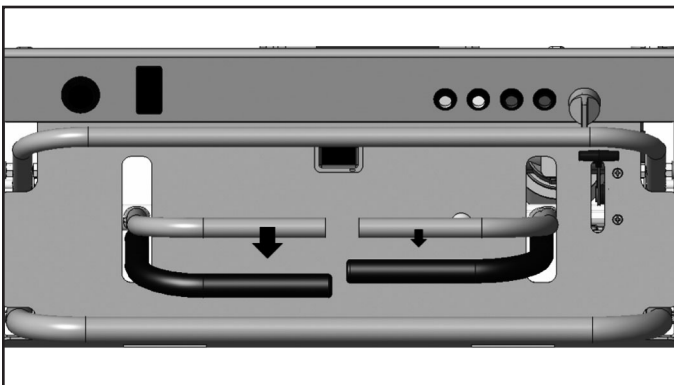

BACKING TO THE RIGHT

Speed Lock- Used to increase and decrease the amount of ground speed the unit has regardless of engine speed. “Slow is Pro” when doing detail work.

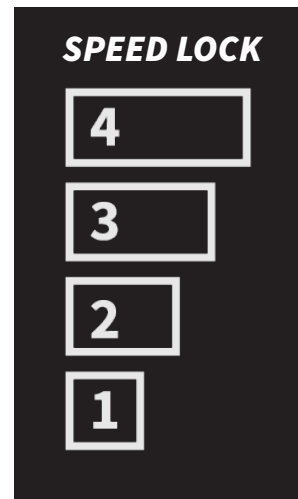

Ignition Switch/ Key- Has 3 positions, start, run, and off. Note: the key must be in the “ON” position for any electrical accessories to function.

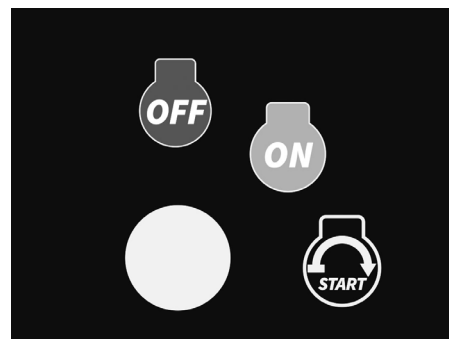

Hydraulic Function Control Handles- Described below from LEFT to RIGHT when standing on the unit.

Left Bent Handle: used to lift/lower the mid mount attachment system.

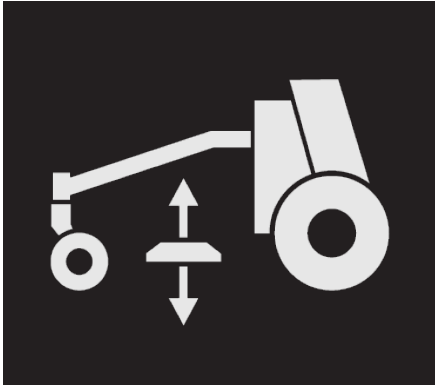

Middle Handle: Used to change tilt of mid mount attachment system.



Right Handle: Used to control the rear hydraulic ports.

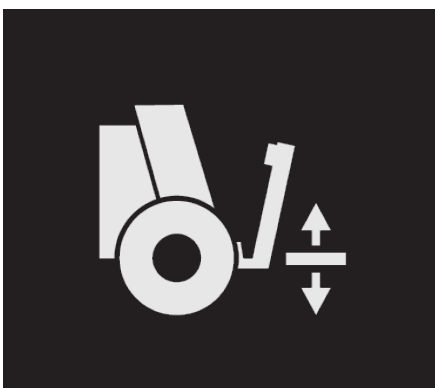

Indicator Lights/Auxiliary- Described below from RIGHT to LEFT when standing on the unit.

Hydraulic Level Indicator: Illuminates when hydraulic fluid is low.



Check Engine Oil Indicator: Illuminates when engine oil is low.



Malfunction Indicator Lamp: Indicates engine issue – see Kohler engine service manual.

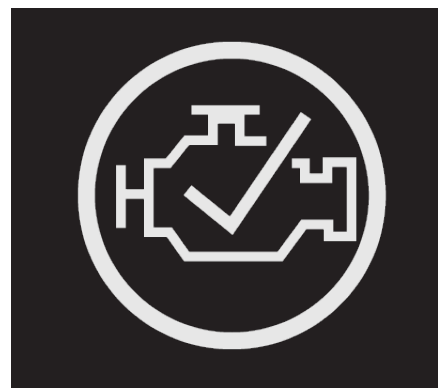

Power Indicator: Illuminates when electrical system is powered on.



USB Charge Port: For auxiliary power needs.

NOTE: SHUT DOWN UNIT IMMEDIATELY AND REPLACE ANY LOW FLUIDS INDICATED BY WARNING LIGHTS.

Standing Operator Rest: Used to change operator positions. Adjusts with pin holes in backrest.

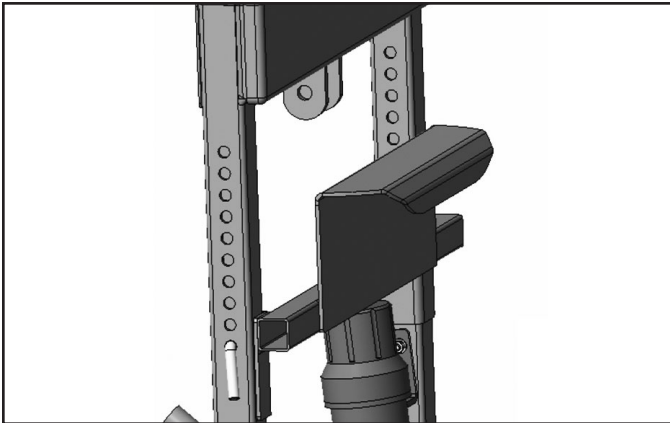

Knee pad – Adjusts for comfort
– Change position with bolts on back of panel

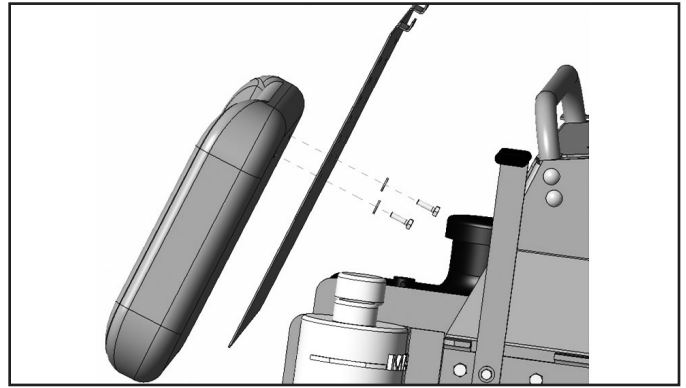

Hour Meter – Provides hours of operation, tachometer, timer, and unit maintenance reminders. Pressing the button will cycle thru the functions, holding it down will reset the timers and maintenance minders.



Messages displayed are:

“chg OIL & filter” - change engine oil and oil filter

“chg H OIL &filter” - change hydraulic system oil and filter

“LUB” - Lubricate pump drive shaft

Attachment Systems

There are 3 main areas to add attachments to the ABI Force:

1. Front quick connect system – instructions provided with attachments or at www.abisupport.com

2. Mid-Mount Attachment System

3. Rear Connection and hitch

Mid-Mount Attachment System

This section is designed to show setup of the mid-mount attachment system for use. Popular attachments include the VibraFlex, Profile Blades, and mini-box blade. For additional information on operating these attachments, see attachments specific manual/instructions.



WARNING! Keep all limbs clear of moving parts while installing or adjusting any attachments on the ABI Force. Fully lower all attachments to the ground prior to disconnection.

1. All mid-mount attachments utilize a universal set of brackets called "pockets" to attach to the mid-mount system. See **Figure 8**.

2. The mid-mount attachment carrier can be lifted and pitched into an orientation that allows connection into the pockets by using the hydraulic controls. Attachments are secured using pins inserted into holes and pockets.

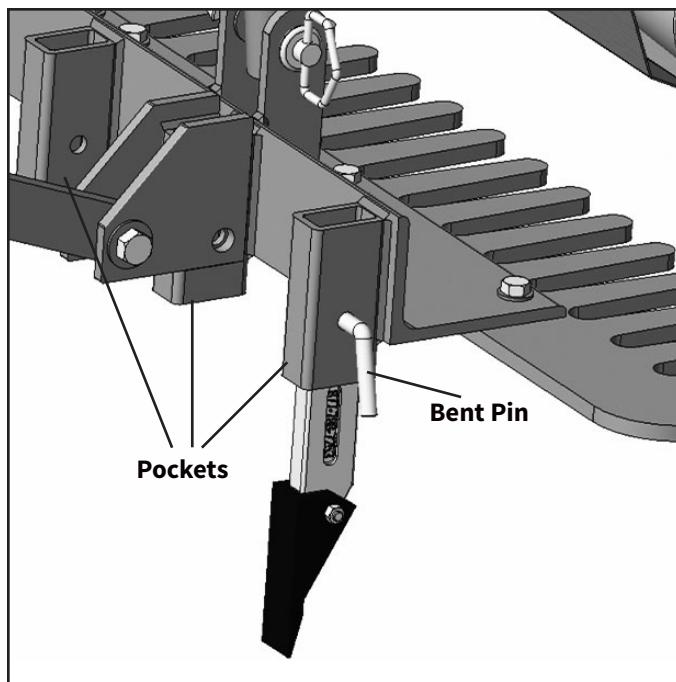

Figure 8: Scarifier installation

Note: Different attachments use different combinations of pockets. See attachment manual for details.

3. The optional multifunction rake on the Mid-mount attachment system is also used for attachments such as the mini box blade. The mini box is a "drive over" attachment that clamps to the rake with wing nuts. After aligning the box connection plates with the rake teeth use clamp plate and wing nut to attach box to rake. Tighten with provided torque bar stored on the backrest.

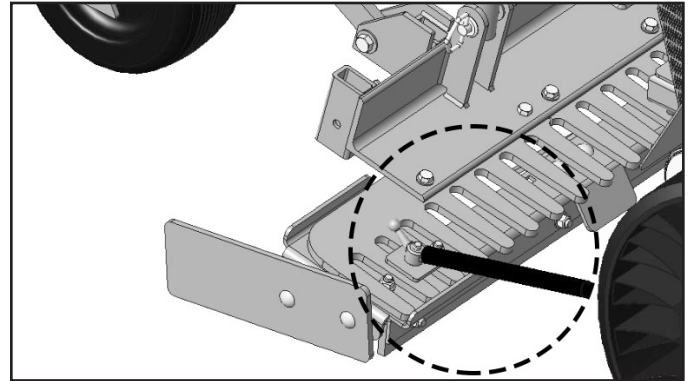

Figure 9: Mini-box clamp rotate

Setting the Depth of the Mid-Mount System:

Each of the mid-mount attachments can have the working depth set rigidly to a stop point or be allowed to adjust on the fly.

Depth using Depth lock and set collars:

With the desired attachment connected to the mid mount attachment system:

- 1.** Fully raise the attachment.
- 2.** Turn off the engine, and set the park brake.
- 3.** Flip the depth lock over the shaft of the hydraulic lift ram. Using the provided stop collars and the flip over depth lock, set the downward stroke of the cylinder.

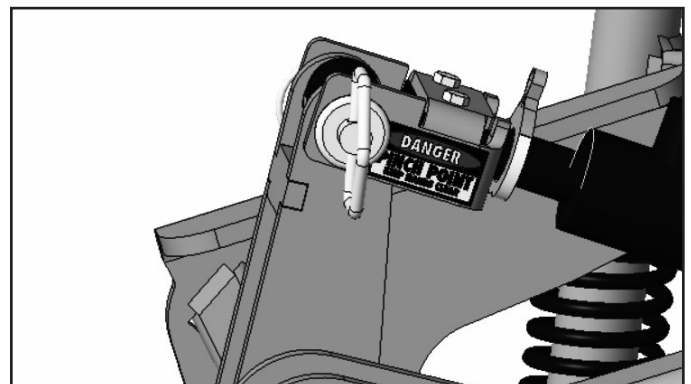

Figure 10: Depth-lock

Return to the operators station and check depth setting in the desired material. Care must be taken not to damage any sub grade or base while setting depth.

Leveling the Mid-mount System

Due to manufacturing variations, it may be necessary to adjust the pitch of the mid mount attachment system, especially when doing fine finish laser grading. With the mid mount system on a flat, hard surface such as concrete, determine which side is high. If adjustments were needed, the right hand side compression spring is adjustable as follows:

1. Place mid mount system on the ground to remove pressure from the compression spring.
2. Remove the pin from the bottom of the compression spring assembly, attaching it to the mid mount system.
NOTE: The 2 washers between the spring tube and the ears. Be aware there may still be some pressure on the pin and the spring tube may shift.
3. Using supplied allen wrench, loosen lower collar on spring to allow the lower spring tube section to move. Move it away from the bolt in the lower spring tube assembly.

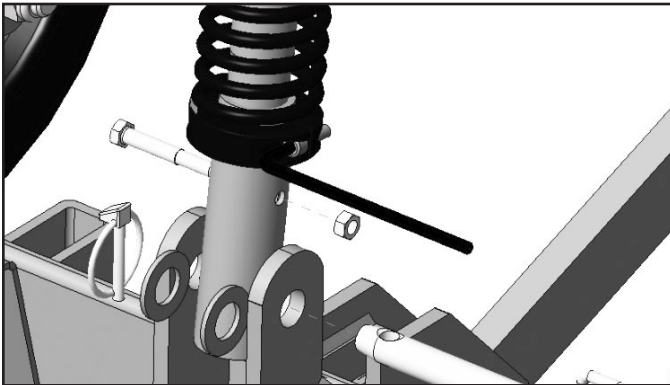

Figure 11: Lower spring disassembly

4. Remove the bolt in the lower spring tube assembly with a 1/2" wrench.
5. Screw the lower spring tube assembly in or out as needed to level the mid mount system.

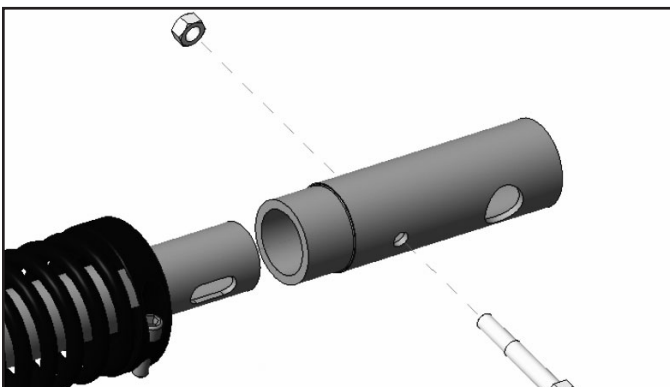

Figure 12

7. Reassembly is the reverse order. Ensure spring collar rests against bolt on bottom of compression spring assembly.

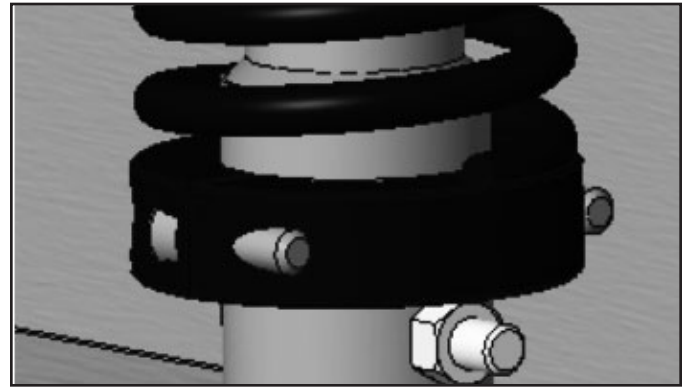

Figure 13: Spring rests on bolt

Removing the Mid-mount attachment system from the ABI Force

The mid-mount attachment system can be removed from the ABI Force to allow other attachments. To allow for better support, remove the mid mount attachment system with one of the attachments such as profile blades or scarifiers inserted into the pockets.

NOTE: To operator- Ensure there is adequate space for the ABI Force to maneuver around the mid-mount attachment system when removing. Ensure the area is free of dips, obstacles, and other hazards.

1. Lower the mid-mount system to rest on the ground. Make sure the springs are loose on their pins. Not bound.
2. Shut off the ABI Force, engage the parking brake and dismantle the unit.
3. The lynch pin securing the bottom of the compression springs from the securing pin. Note the 2 washers between the spring tube and the ears. Be aware there may still be some pressure on the pin and the spring tube may shift. Next, remove the clip from the top of the compression spring. Set the compression spring off to the side. Repeat on the opposite side.

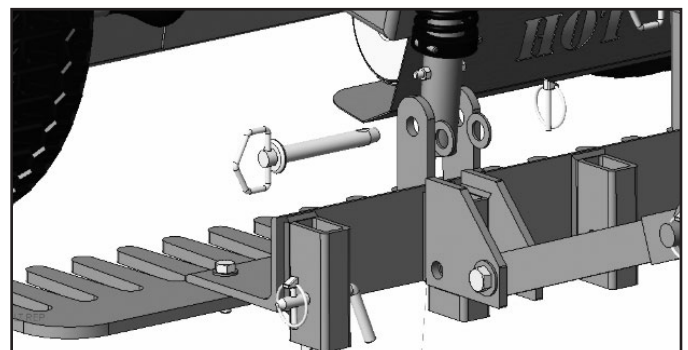

Figure 14: Remove bottom pin first

4. Next disconnect the center lift chain for the mid-mount attachment system from the lift arm. This may require starting the unit and lowering the mid-mount system all the way down. When removing the securing pin ensure the spacers are not lost. This chain should stay attached to the mid mount unit for storage.

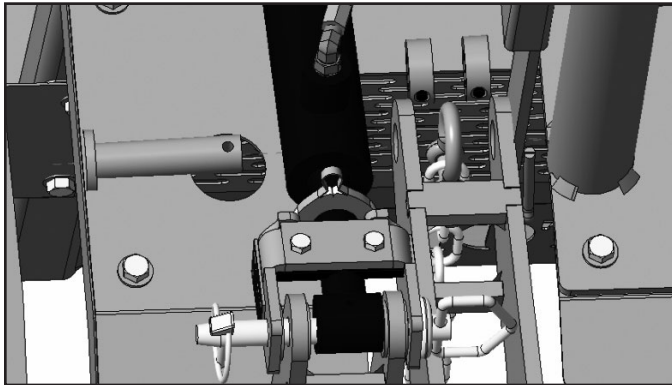

Figure 15: Center lift chain

5. Next, locate the latches securing the support rod for the mid-mount attachment system. This rod is held in place on both sides of the ABI Force by a flip over latch.

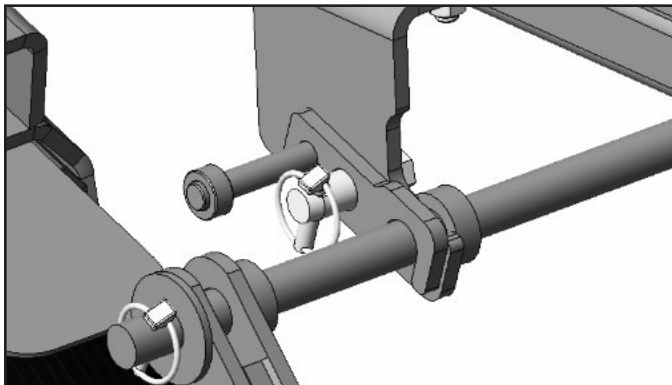

Figure 16: Support rod

6. Pull the lynch pin from the center pin of the latch and slide bracket off the pin and flip it out of the way of the rod. Repeat this process on the opposite side of the ABI Force.

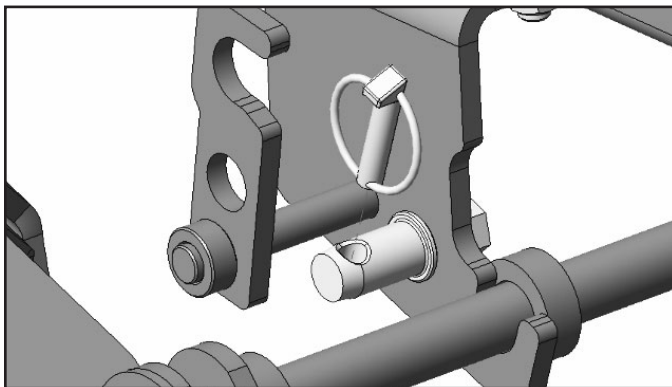

Figure 17: Flip latch to remove

7. With both latches disengaged, gently lift up and flip the support rod off of its support brackets. Once the support rod is removed, flip the latches over and secure them back in place using the lynch pin that was previously removed.

Note: Store flip latches in locked position to prevent damage to them.

8. Now pin up the pitch control hydraulic ram to the chassis of the ABI Force. To release the hydraulic ram disconnect the pin holding the mid-mount attachment system to the hydraulic ram. Use the chain provided with the other mid-mount attachment to secure the cylinder under the Force.

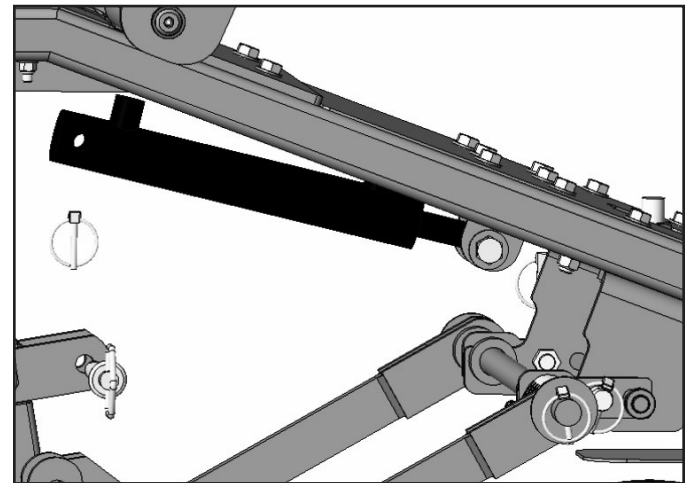

Figure 18: Pitch cylinder storage location

9. With all connection points disconnected, mount the ABI Force and start the unit.

10. Slowly begin to pivot the ABI Force off the mid-mount attachment system, being careful to ensure that no part of the mid-mount attachment system catches on the chassis of the ABI Force.

11. Reattach the compression springs back to the frame of the multi-function attachment system. This will ensure they are not damaged or misplaced. The ABI Force is now ready for use with other mid-mount attachments.

Note: Installation is the reversal of removal.

Rear-Mount Attachments:

The rear-mount attachments for the ABI Force are connected one of three ways:

1. Drag connect ears – chain connections for dragging various mats with manual adjustment and lift.
2. Hydraulic Rear lift – allows articulation of attachment, as well as some adjustment and lifting on the fly.
3. Trailer hitch – standard 1 ¼” trailer hitch.

Using Drag Connect Ears

Chains are attached to each ear using spring loaded clips. The other end of the chain is connected to a pull-behind drag mat type attachment. This style of attachment is adjusted by changing the length of the connection chains.

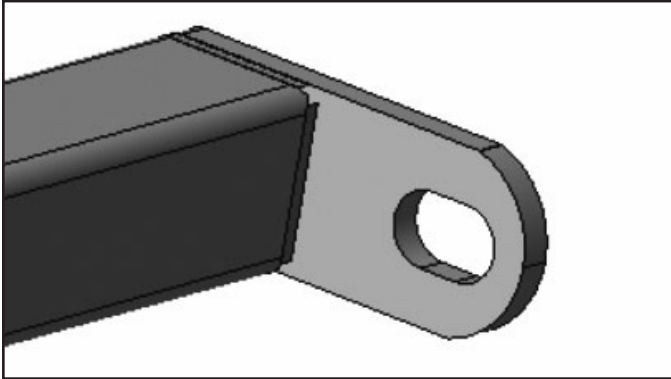

Figure 19: Dragmat ears

Hydraulic Rear Lift: INSTALLATION

1. Secure the lift arm to the bottom mount bracket using the provided pin.
2. Attach the hydraulic ram to the top mount bracket using the provided pin. Ensure the hydraulic hoses are facing right when viewed from the rear.
3. Plug in hydraulic connections to rear quick connect ports.

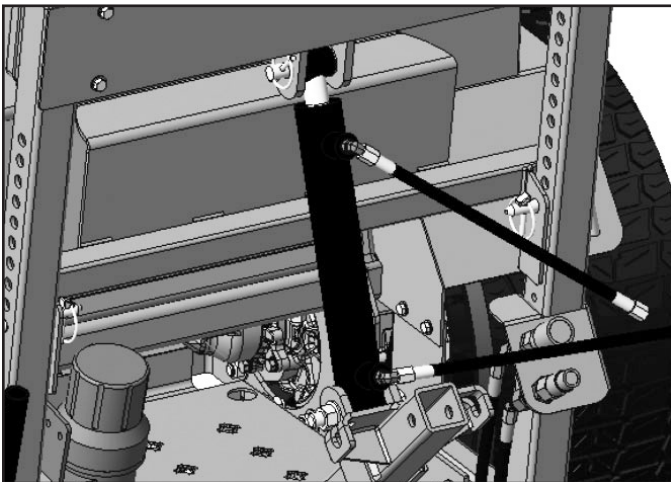

Figure 20: Rear lift installed

4. Use the right hydraulic function control lever to lift/lower the rear hydraulic lift arm.

Hydraulic Rear Lift: USE

Attachments can be lifted by attaching chains to the lift arms on the provided slots. See **Figure 21**. If the articulating rear hitch system is used then these slots provide the lift for it.

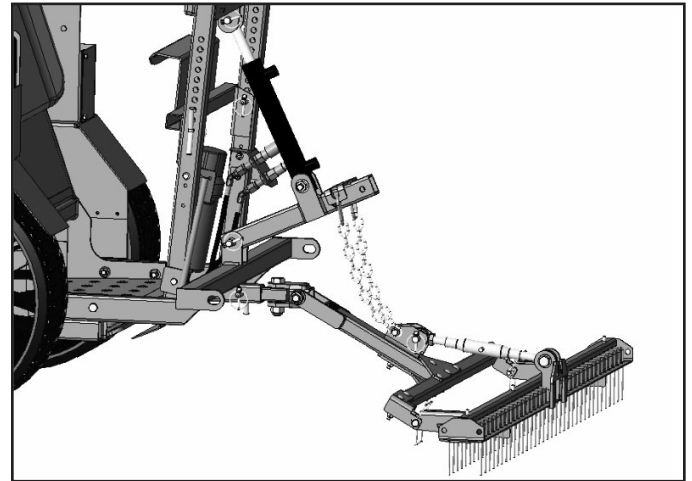

Figure 21: Rear lift attachment

Trailer Hitch

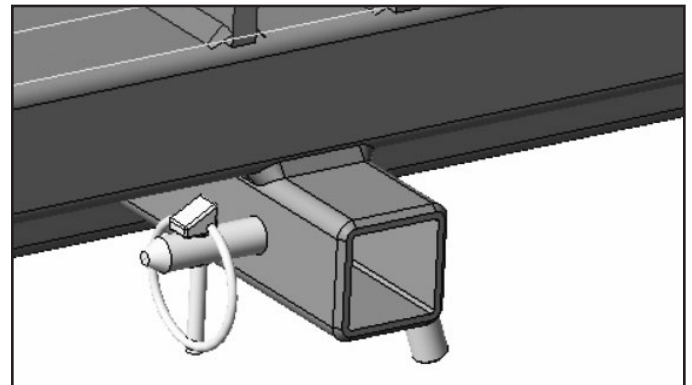

Figure 22: Trailer hitch



WARNING! Never attach any non-approved attachment to rear of the ABI Force. Handling, stability, and control could all be affected.



WARNING! Never exceed 750 lbs towed/100 lbs tongue weight and always stay on level surfaces. Damage to equipment and injury could result.

Maintenance

Service Schedule

Daily

Check Engine Oil	SAE 30 or 5w-40 Full Synth Engine Oil
Check Hydraulic Oil	SAE 5w-40 Full Synth or equivalent
Check Fuel	87 Octane E10 or less Regular Gasoline
Check Tire Pressures	Front 25 psi Rear 20 psi
Blow out engine compartment and cooling fans	
Check attachment wear parts	

After First 25 Hours

Change Engine Oil and Filter	5w-40 Full Synth Oil	Kohler part 52 050 02-S filter
Check Lugnut torque	90-120 ft lbs	

Every 50 Hours of Operation

Blow out engine compartment and cooling fans	
Grease pivot points and front wheels	
Inspect Outer Air filter element	Kohler part 25 083 01-S
Inspect for loose fasteners	
Inspect hydraulics for leaks and moving hoses for damage	

After First 100 Hours

Change Hydraulic Oil and Filter	5w-40 Full Synth Oil	Lenz CP-752-10 Filter
Check Lugnut Torque	90-120 ft lbs	

Every 100 Hours of Operation

Change Engine Oil and Filter	5w-40 Full Synth Oil	Kohler part 52 050 02-S filter
Check Lugnut Torque	90-120 ft lbs	

Every 200 Hours of Operation

Replace Fuel Filter (EFI specific)	Kohler part 25 050 42-S or equivalent
------------------------------------	---------------------------------------

Every 300 Hours of Operation

Replace Inner Air Filter element	Kohler part 25 083 04-S
----------------------------------	-------------------------

Every 500 Hours of Operation

Change Hydraulic Oil and Filter	5w-40 Full Synth Oil	Lenz CP-752-10 Filter
Lubricate Pump Driveshaft	Kohler part 25 357 12-S or equivalent	
Replace Spark Plugs and set gap	Kohler part 25 132 12-S at 0.03" gap	

NOTE: Maintenance is critical to ensuring the longevity of the ABI Force. Failure to perform necessary maintenance could void the warranty. For additional information on maintaining the ABI Force contact Customer Support.

Maintenance Safety Rules:

- Never perform maintenance on the ABI Forcer when children are present.
- Never perform service or maintenance on the engine of the ABI Force while it is hot. Always have the engine off with the park brake set.
- Never allow anyone near the operations controls while performing service or maintenance on the ABI Force.
- Always remove any accumulated debris, fuel, excess grease, or excess oil from within the chassis of the ABI Force to prevent a fire hazard.
- Never use the engine area of the ABI Force for storage of flammable substance or harmful chemicals.
- Never allow an open flame source inside the ABI Force chassis.
- Always dispose of hazardous substances according to local regulations.

Engine Maintenance Note:

- Always use OEM replacement parts for the engine. Non-OEM parts may not perform as well, may cause damage to the engine, and may result in injury! Specific fuel filter and spline lube are required to maintain engine warranty.
- Follow engine manual for oil recommendations. The same 5W-40 full synthetic used in the hydraulic system is acceptable in the engine but not required.
- Use only 87 octane E10 or less Gasoline (87AKI/91 RON).
DO NOT USE E-15 OR E-85.

Hydraulic System Note:

- The ABI Force uses a sophisticated commercial duty hydraulic drive and auxiliary pump system. Proper fluids and service are essential to maintain the longevity of the system.
- Only 5w-40 FULL SYNTHETIC motor oil is to be used in hydraulic system, no other fluids are permitted or warranty is void.

Cover Removal

Access is easily gained to the engine compartment by removing the covers as follows:

Rear:

Lift bottom of knee pad panel upward and rearward until pad and plate are horizontal with dashboard. Then pull knee pad panel towards the rear of the machine while lifting at the attachment to remove.

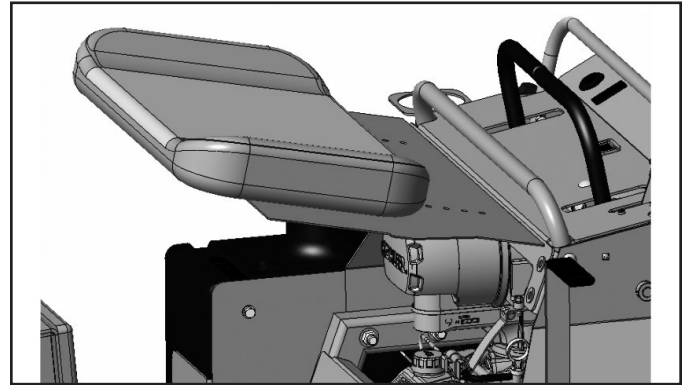

Figure 23: Knee pad removal

The bottom rear cover is removed by pulling up on the flange and pivoting outward. Cover will then lift clear of the machine.

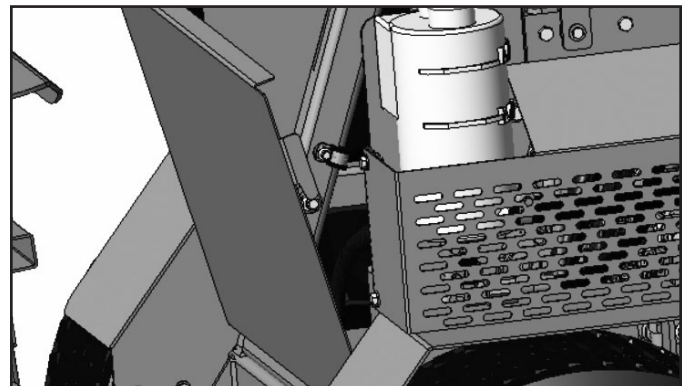

Figure 24: Bottom rear cover removal

NOTE: Velcro pads hold both covers to prevent rattles during operation.

Side & Front:

Loosen front lower cover bolts with a 9/16" wrench. Do not remove unless removing of the lower front cover is also desired. Remove the 2 top bolts on each side with the same 9/16" wrench. The nut is captive on the frame, so only one wrench is needed on all cover bolts. The right side cover will require removing the bolts next to the operators station with a 1/2" wrench. See figures 25, 26, 27.

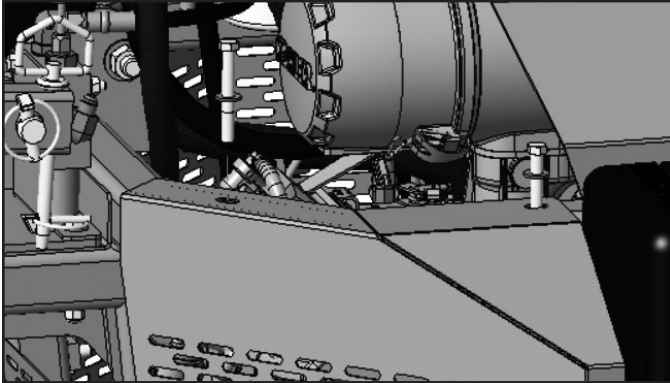

Figure 25: Left side cover bolts

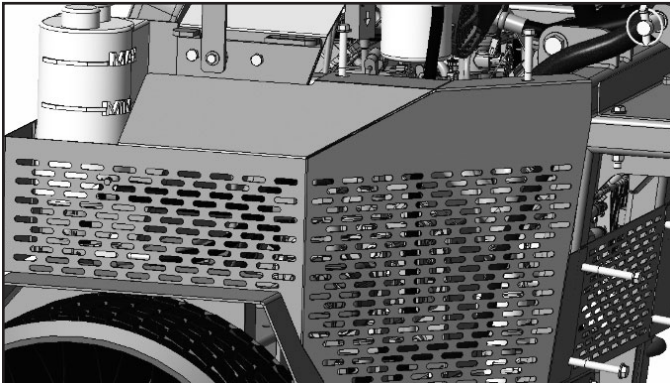

Figure 26: Right side cover bolts

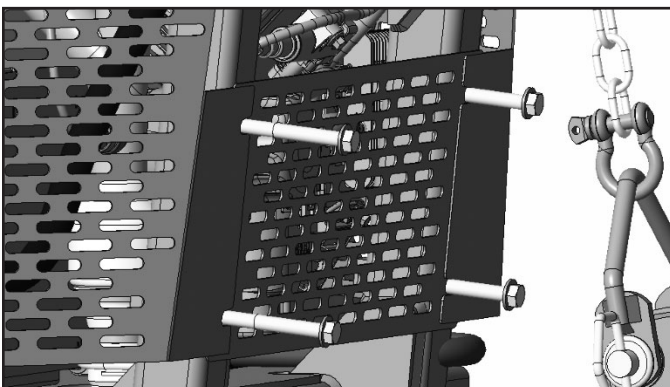

Figure 27: Lower front cover bolts

Daily Maintenance Checks

(Every 8 hours of operation)

Checking Engine Oil:

Engine oil and fill are under the rear knee pad panel. With unit on a level surface fully insert dipstick and remove to read. The level should be within the hatch area. Use oil recommended in Kohler engine manual or the same 5w-40 Full Synthetic Motor Oil used in the Hydraulic System.

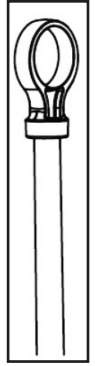

Figure 28: Dipstick

Checking Hydraulic Oil:

Observe markings on the side of the hydraulic reservoir and maintain levels 1/2 way between "MIN" and "MAX". Use SAE 5W-40 oil such as Mobil DELVAC 1 ESP (Diesel Engine Oil). If hydraulic oil dash light stays lit refill fluid immediately or discontinue use of machine until fluid can be refilled.

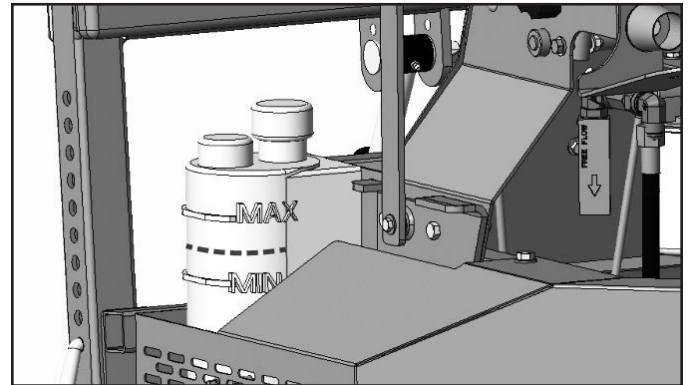

Figure 29: Hydraulic fluid level - ideal Cold level

NOTE: Operating unit with low levels of hydraulic fluid for long periods of time will damage the hydraulic pumps and will not be covered under warranty.

Fuel:

Use clean, fresh regular unleaded gasoline with 87 octane or higher. **Never use gasoline containing methanol or gasoline containing more than 10% ethanol because the fuel system may be damaged.**

Tire Pressures:

Maintain front tires at 25 psi (172 kpa) and rear tires at 20 psi (138 kpa).

After Operation:

- Remove any build up or debris from under/around the chassis of the ABI Force. This is best done with an air hose. If using water do not direct any water under the top of the dash, wiring damage may result.
- With use of Optional Attachment After using seeder/fertilizer spreader: Blow any excess seed or fertilizer that may be on the ABI Force off with an air hose. Water may accelerate corrosion.

After the first 25 hours of operation

Changing Engine Oil & Oil Filter:

- Ensure unit engine is stopped and is not hot but is still warm.
- Using a 9/16" wrench, remove the center cover bolts in front of frame.
- Route rubber oil drain hose over the edge of the frame to point at a drain pan. Using 11/16 wrench and an adjustable wrench remove the hose end cap and drain engine oil into pan. See figure 30

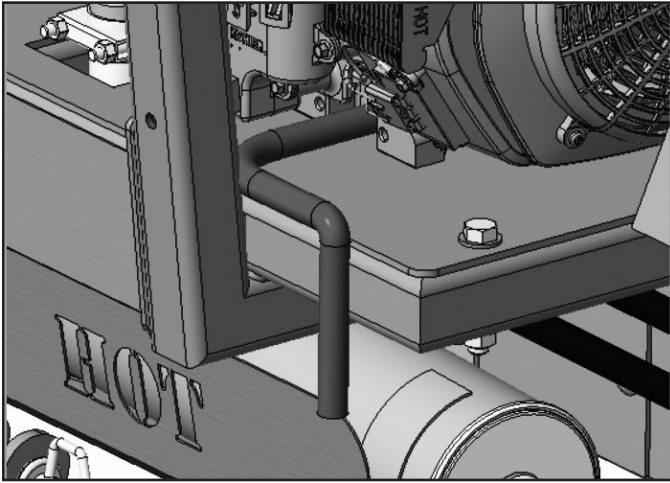

Figure 30: Oil drain hose

- With oil drained, spin off oil filter located at front of unit. Replace with Kohler part number 52 050 02-S filter.

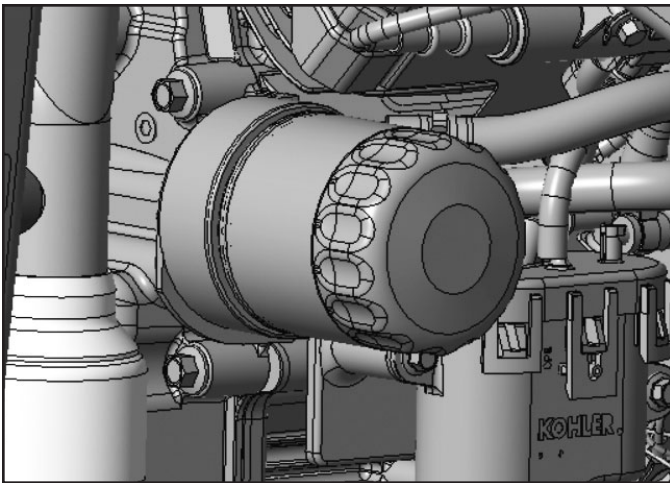

Figure 31: Oil filter location

Wipe filter area to remove any dirt before reinstallation. With open end up, fill new oil filter with new oil until oil reaches bottom of the treads. Allow 2 minutes for the oil to be absorbed by the filter material before installation. Lubricate seal of oil filter with engine oil before installing.

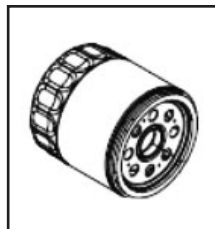

Figure 32: Oil filter

- With oil filter reinstalled and drain hose resealed, locate oil fill cap (accessible with the lower engine cover removed.)

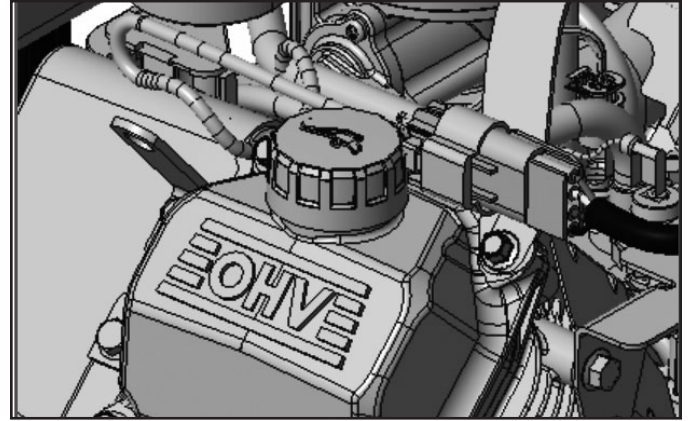

Figure 33: Oil fill cap

- Refill oil with grade as specified in engine owners manual.
- Start engine and check for leaks. Correct all leaks before putting unit back into service.
- *The same 10w-40 full synthetic used in the hydraulic system is acceptable after the initial break in period but is not required.*

• DISPOSE OF USED OIL BASED ON FEDERAL OR LOCAL GUIDELINES

Torque Lugnuts

Lug nuts should be torqued to 90-120 ft lbs

Weekly Maintenance Checks

(every 50 hours of operation)

Inspect the air filter

The canister style air filter is inspected by removing the cap from the front left side of the ABI Force. Detach clips and pull primary filter from housing. Replace if clogged. Inner air filter should be changed every 300 hours or when it becomes clogged.

NOTE: It's easy to damage an air filter by cleaning it with compressed air. A faulty air filter will allow dirt into the engine that could cause damage to internal components. If you are reusing the existing filter element make sure the sealing surface isn't damaged before installation. Never run engine with inner air filter removed, engine damage may result.

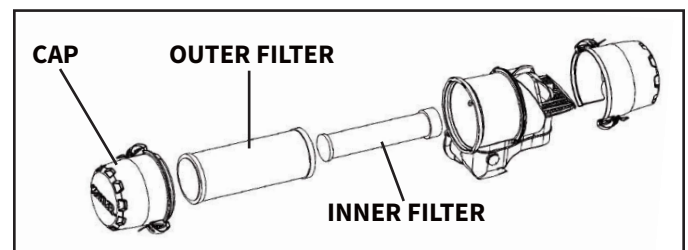

Figure 34: Air filter assembly

Cleaning the Force:

Using compressed air, blow down engine compartment, including engine and hydraulic cooling fins. This is most easily done by removing the rear engine covers and blowing the dirt forward.

NOTE: Use of a hose or power washer is not recommended. If using water never direct it at the underside of the dash.

Grease Points:

- Front Axle 2 places. See **Figure 35**
- Front wheels 2 places. See **Figure 35**

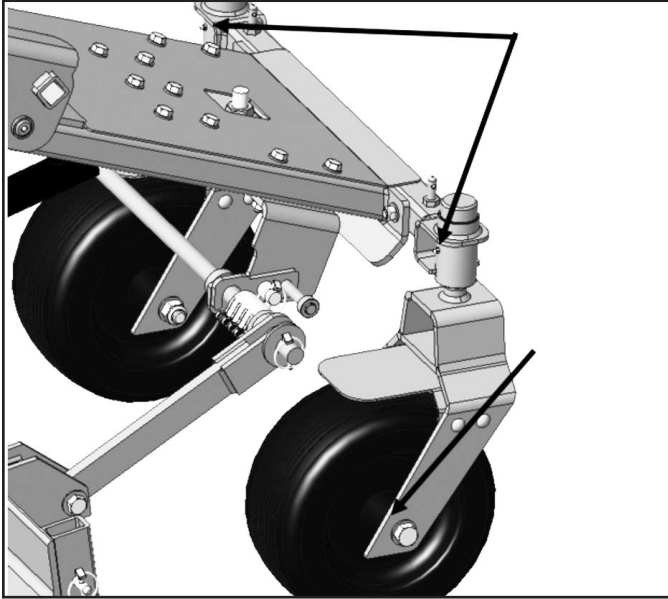

Figure 35: Front axle grease points

- Hydraulic cylinders 2 places each. See **Figure 36**

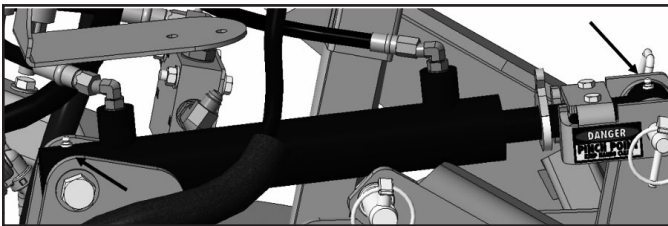

Figure 36: Hydraulic cylinder grease points

General Maintenance

Jacking the machine:

1. Use jack stands, block wheels and never place any body part under machine while raising.
2. Always use park brake when raising front of machine.
3. Only lift from and support on frame, never on moveable parts of the machine.

4. See **Figure 37** for suggested jack placement.

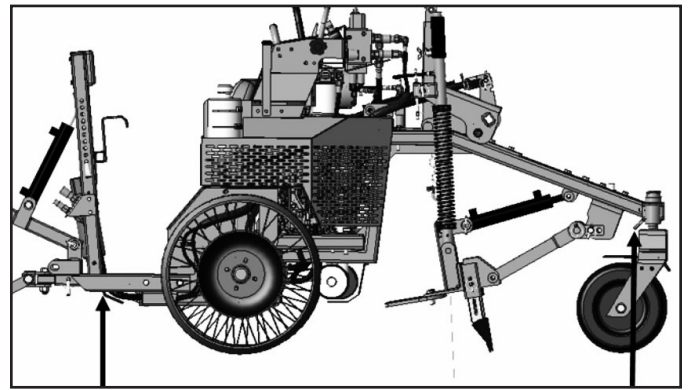

Figure 37

Towing the machine:

1. Only tow slowly and limit distance towed.
2. Raise or remove all attachments before towing disabled machine.
3. Move unit by “dumping” drive system. This is done by loosening dump valve nuts on both pumps as shown in **Figure 38**. Do not completely remove.

Note: After “dumping” the system the pumps will have to be readjusted to enable the machine to track true.

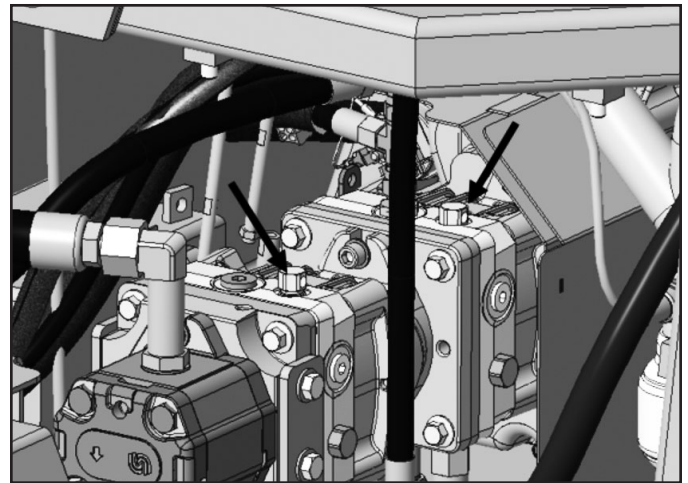

Figure 38: Hydraulic dump valves

Drive system adjustments:

1. To make drive handles straight:
 - Check that all linkages between control handles and pumps are tight and drive handles align.

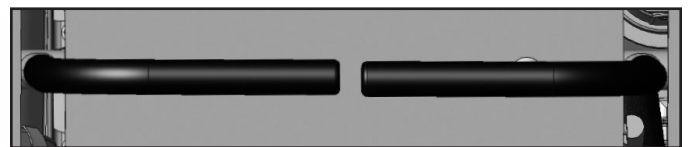

Figure 39: Drive handles

- If adjustment is needed to drive handles loosen jam nuts with ½” wrench and turn control rod to proper length. Retighten jam nuts to lock rod in place. See **Figure 40**

2. To make the machine drive straight:

- Tighten both dump valve nuts snug. See **Figure 38** from towing the machine for location.
- Test drive machine in open, level, clear area. Set Speed-lock to 3 or less and hold handles firmly against Speed-lock bar.
- To correct any veering to the right or left, both jam nuts on one of the Control Rods need to be loosened. The jam nuts to the top of the rods are Right Hand Threads and must be turned clockwise (turn to the left) to loosen and counter-clockwise (turn to the right) to tighten. The jam nuts to the bottom of the rods are Left Hand Threads and must be turned clockwise (turn to the left) to loosen and counter-clockwise (turn to the right) to tighten.

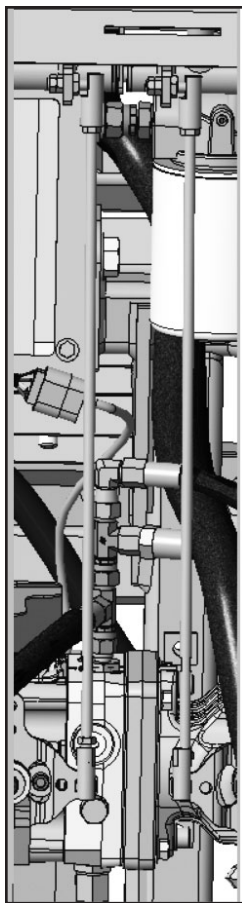

Figure 40: Drive control rods

If veering to the **left**, once the two jam nuts are loosened on the Left Control Rod, rotate the Control Rod slightly counter-clockwise (turn to the right). Re-tighten the jam nuts and test the unit. If still veering left, repeat turning the Control Rod.

If veering to the **right**, once the two jam nuts are loosened on the Right Control Rod, rotate the Control Rod slightly counter-clockwise (turn to the right). Re-tighten the jam nuts and test the unit. If still veering right, repeat turning the Control Rod.



WARNING! Engine and exhaust will be hot – wear heat resistant gloves and do not touch hot surfaces. Do not push wiring up against hot surfaces. Make certain the red boot on the positive terminal on the battery completely covers the positive terminal to avoid contact with wrench.

3. Parking brake adjustment:

- The only adjustment is to the linkage system, the internal wet disk brake is not adjustable on the wheel motor.
- To adjust the linkage, loosen jam nuts with ½” wrench and turn control rod to tighten or loosen. Retighten jam nuts and confirm that brake still engages, disengages, and handle moves freely.

Replacing Hydraulic Oil & Filter

(First 100 hours and every 500 hours after)



WARNING! Hydraulic Oil is hot during normal operation and can burn. Do not open hydraulic system with hot oil under pressure!

Note: It is impossible and unnecessary to drain the entire hydraulic system. This procedure will replace enough of the oil to preserve the life of the unit.

- 1.** Block front tires and jack rear of unit per jacking instructions. With unit cool to slightly warm locate the oil supply hose as shown in **Figure 41**.

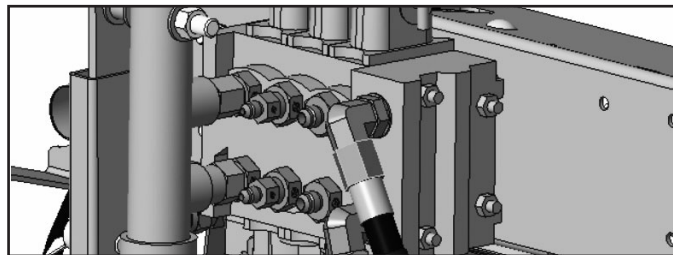

Figure 41: Main control hose

- 2.** With a catch pan in place, use a 1” wrench to remove the hose at the valve end, supporting the other end of the valve fitting with a backhold wrench to prevent movement.

- 3.** Feed the loose end of the hose behind the covers to a suitable drain pan.

- 4.** Remove rear tires with a ¾” socket and loosen lower motor hose on each side as shown in **Figure 43** with a 7/8” wrench. Route hose to an appropriate catch pan.

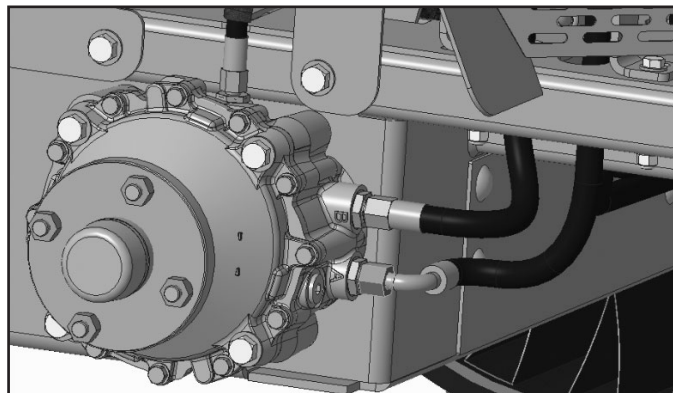

Figure 42: Motor hose location

- 5.** Remove spark plug wires from engine to allow it to crank but not run.

- 6.** Crank engine to allow pump to move fluid trapped in system to be removed. Crank for 5 seconds at a time, allowing starter to rest for 30 seconds in between cranks. Engage drive handles in reverse while cranking.

- 7.** Stop cranking when hydraulic reservoir is empty. **Do not continue to crank with reservoir dry.**

8. Locate and remove the hydraulic oil filter under the dash. Be careful not to spill the oil in the filter. Pre-fill new filter with fresh oil, allowing filter paper to absorb the oil before reinstalling.

NOTE: Filter must be replaced with same size and type (10 micron) or warranty is void. See **Figure 43**.

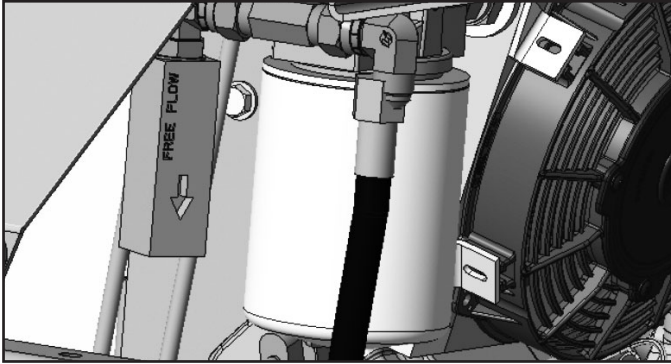

Figure 43: Hydraulic filter location

9. Reinstall hose to hydraulic valve, ensuring fittings are clean and tight. Torque to 62 ft lbs.

10. Reinstall hose to wheel motors, Torque to 37 ft lbs.

11. Replace spark plug wires and any covers removed. Fill reservoir to “max” line with hydraulic oil.

12. Follow hydraulic system bleeding instructions and inspect for leaks before putting unit back into service.

Hydraulic System Bleeding



WARNING! If air is present in the hydraulic system, such as after a fluid or filter change, machine controls may be unresponsive or erratic. Use extreme caution when operating unit until it is fully bleed of air.

1. Block front tires and lift rear wheels off ground to prevent machine from moving while drive is engaged. Do not use park brake.

2. Ensure reservoir is filled to max line and start engine at low idle.

3. Watch reservoir level, shutting off machine when it drops to “min” level line.

4. Refill the unit and restart engine, again watching for oil level to drop. **Note:** level may drop very quickly at first, triggering the low oil light on the dash.

5. Throttle up engine once level stabilizes at idle. As you check and add hydraulic oil, begin to engage hydraulic drive levers. Run both forward and backward to circulate oil in the system. **Note:** shutting down and restarting the engine will allow for faster bleeding.

6. Move the hydraulic cylinders by moving all 3 control handles. Watch for moving attachments.

7. When oil level stabilizes and controls respond consistently unit can be dropped to the ground and driven.

8. Drive unit carefully; check hydraulic oil level often. Do not overfill.

Electric System

Fuse Location

1. Main fuse for the machine is located at the battery under the main rear cover. Note a second fuse is in the same locatoin for powering the optional laser grading system. The main system fuse and laser system fuse are both a 20 amp ATC style fuse.

2. A secondary fuse is located under the dash for the auxiliary power system. It is a 7.5 amp ATC style fuse.

Relay Location

1. There are 2 relays under the dash of the machine.

- The left one powers the cooling fan for the hydraulic system.
- The right one powers the low hydraulic oil indicator light.

Battery Inspection/Jump Starting

1. The battery is located under the main rear cover.

2. Disconnect laser grading system and any other electrical accessories.

3. Ensure terminals are tight and clean.

4. Battery should have 12.4v minimum reading with key switch off.

5. Replace with like size and capacity battery.

Fuel System

Note: The ABI Force fuel system contains emissions related components as regulated by the US EPA and California Air Resources Board. Any modification of emissions related components is not permitted and may violate the law.

Replacing the Fuel Filter (every 200 hours)

1. Remove Left side cover.

2. Locate filter in front of engine under frame rail.

3. Remove clamps and replace with Kohler PN 25 050 42-S or exact match only.

Note: use of different fuel filter will void engine warranty. See **Figure 44**

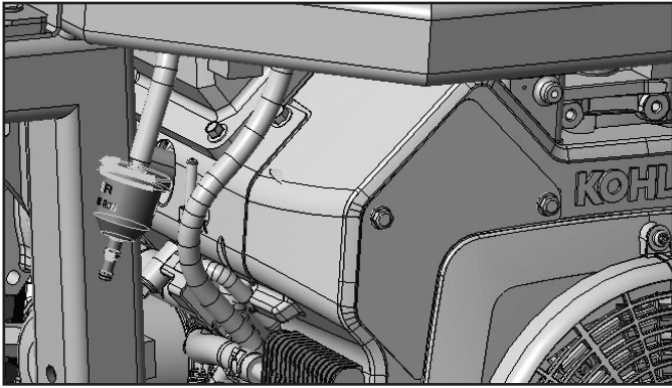

Figure 44: Fuel filter

Engine

Note: See Kohler engine manual for more specifics on engine service.

Replacing Spark Plug:

1. Remove lower front cover.
2. Spark plugs are accessible with a socket extension. Replace with like plug and set gap to .76 mm (0.03 in) See **Figures 45** and **46** for locations.

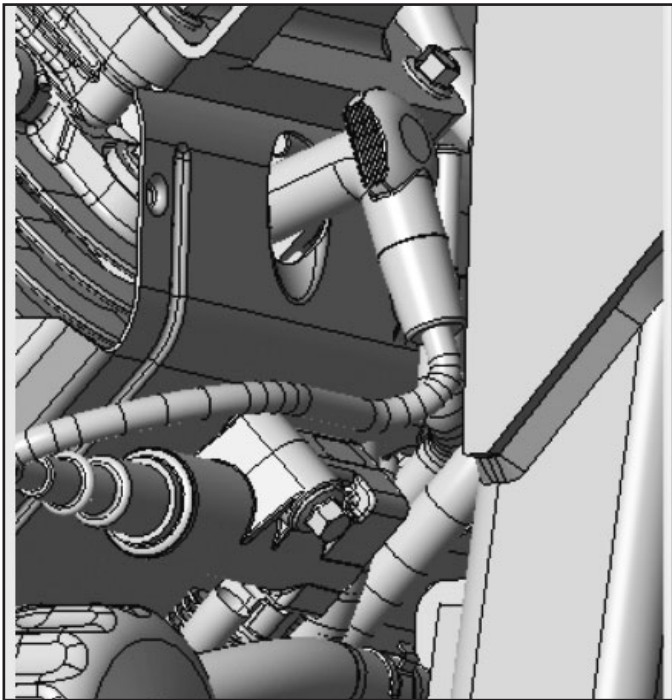

Figure 45: Spark plug location

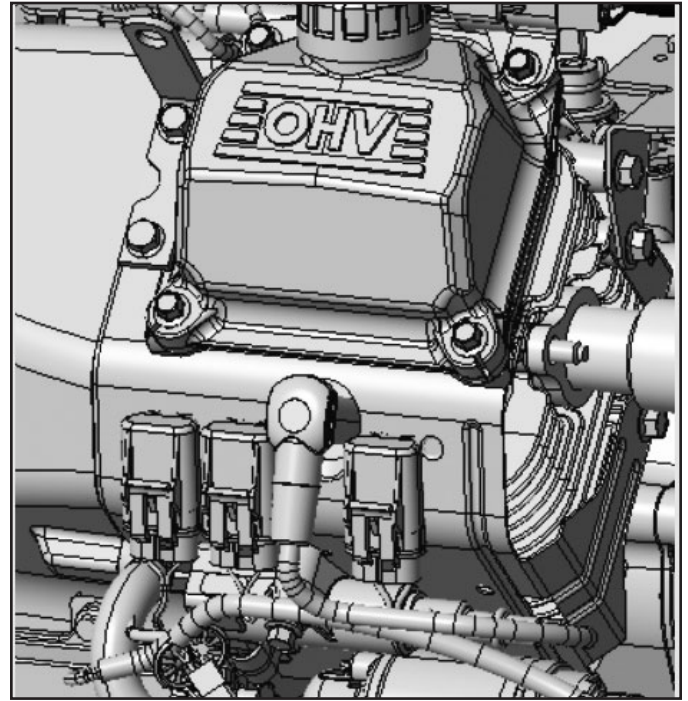

Figure 46: Spark plug location

Throttle Adjustment

1. Remove rear covers.
2. Loosen screw and adjust cable to desired throttle travel. See **Figure 47** for location.

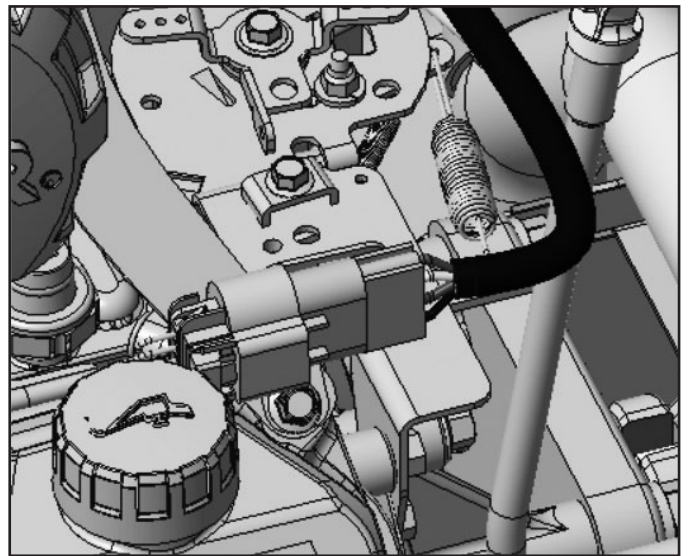

Figure 47: Throttle adjustment screw

Lubrication of Pump Drive Shaft

1. Unit should be cold because of proximity to exhaust system. Set park brake.
2. Remove rear and right side cover.
3. Loosen and remove 2 pump mount flange bolts as shown in **Figure 48**.

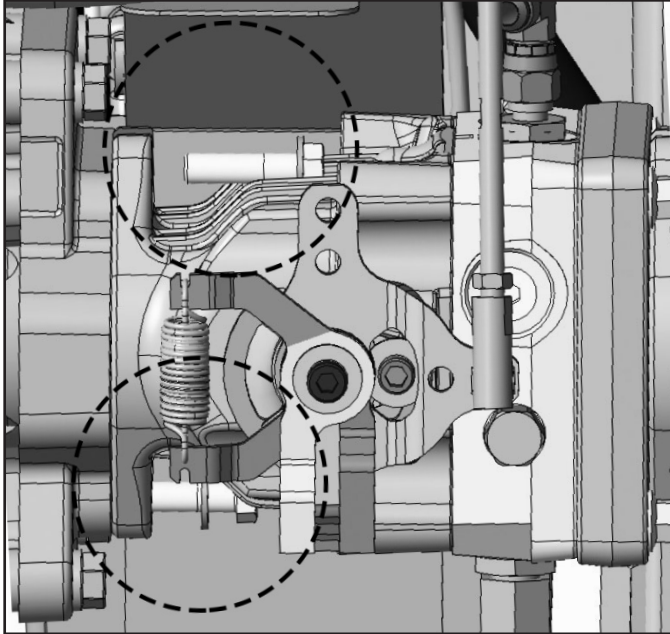

Figure 48: Pump mount bolts

4. Loosen and back out but do not remove 2 pump mount bracket bolts as shown in **Figure 49**.

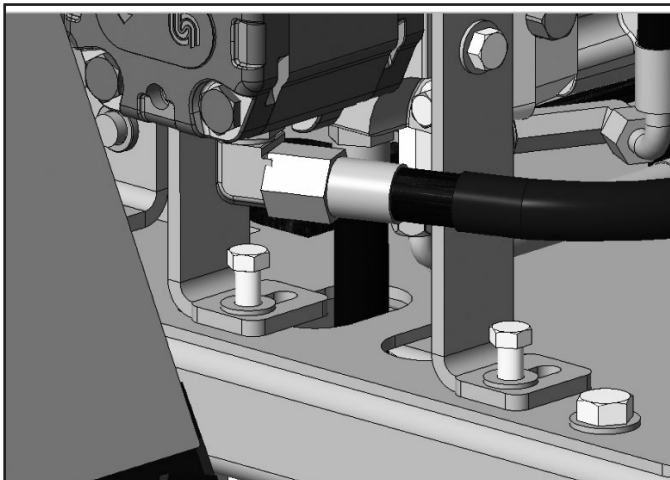

Figure 49: Pump mount bracket bolts

5. Pull on pump assembly to slide it towards right tire of the machine. Exposing the drive shaft of the pump. See **Figure 50**.

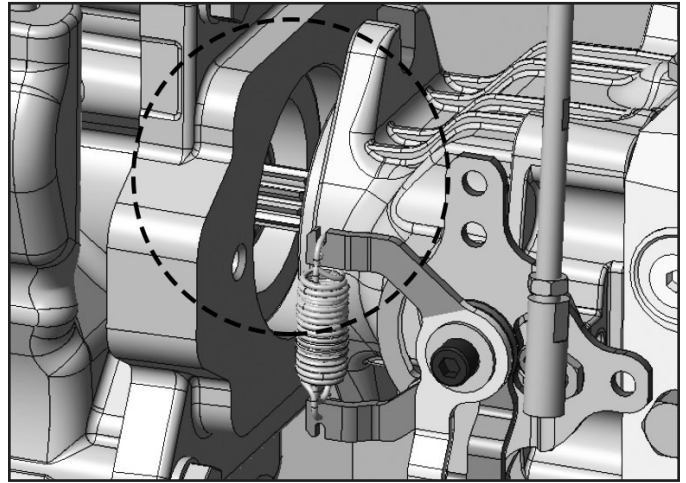

Figure 50: Pump drive shaft

6. Apply Molykote G-n assembly paste to a brush or craft stick and spread on pump spline shaft.
7. Reassemble in reverse order. Apply thread locker to pump mount bolts and torque to 35 ft lbs.

Off Season Storage

- Use a safe dry building with proper ventilation free from pests.
 - Check/refill both engine and hydraulic oil.
 - Wash and Clean Unit.
 - Fill fuel tank completely full using fuel stabilizer treated gasoline.
 - Check tire pressure
Note: If optional Tweel[®] tires sit loaded for long periods of time they will develop a flat spot that rolls out once normal use begins again.
 - Remove battery or place on trickle charger to maintain battery health.
 - Cover Unit (optional)
 - Remove ALL Laser control parts and store in provided case.
-

Service Schedule

Daily

Check Engine Oil	SAE 30 or 5w-40 Full Synth Engine Oil
Check Hydraulic Oil	SAE 5w-40 Full Synth Only
Check Fuel	87 Octane E10 or less Regular Gasoline
Check Tire Pressures	Front 25 psi Rear 20 psi
Blow out engine compartment and cooling fans	
Check attachment wear parts	

After First 25 Hours

Change Engine Oil and Filter	Kohler part 52 050 02-S filter
Check Lugnut torque	90-120 ft lbs

Every 50 Hours of Operation

Grease pivot points and front wheels	
Inspect Outer Air filter element	
Inspect for loose fasteners	Kohler part 25 083 01-S
Inspect hydraulics for leaks and moving hoses for damage	

After First 100 Hours

Change Hydraulic Oil and Filter	5w-40 Full Synth Oil		Lenz CP-752-10 Filter
Check Lugnut Torque	90-120 ft lbs		

Every 100 Hours of Operation

Change Hydraulic Oil and Filter	5w-40 Full Synth Oil		Lenz CP-752-10 Filter
Check Lugnut Torque	90-120 ft lbs		

Every 200 Hours of Operation

Replace Fuel Filter (EFI specific)	Kohler part 25 050 42-S Only
------------------------------------	------------------------------

Every 300 Hours of Operation

Replace Inner Air Filter element	Kohler part 25 083 04-S
----------------------------------	-------------------------

Every 500 Hours of Operation

Change Hydraulic Oil and Filter	5w-40 Full Synth Oil		Lenz CP-752-10 Filter
Lubricate Pump Driveshaft	Kohler part 25 357 12-S only		
Replace Spark Plugs and set gap	Kohler part 25 132 12-S at 0.03" gap		

Kohler EFI Service PN List

Item	Kohler PN	Cross Reference	Note
Air Filter - outer	25 083 01-S	6438 NAPA	Included in Engine Maintenance Kit
Air Filter - Inner	25 083 04-S	2985 NAPA	
Fuel Filter	25 050 42-S		Specific to EFI Engines, included in Engine Maintenance Kit
Engine Oil	25 357 03-S	SAE 30W	Can also use 5w-40 once engine break in is complete
Engine Oil Filter	52 050 02-S	400068 NAPA	Included in Engine Maintenance Kit
Spark Plug	25 132 12-S		Gap to .76 mm (0.03 in)
Shaft Lube	25 357 12-S	Champion RC12YC	Applied to pump drive shaft every 500 hours
Engine Maint Kit	25 789 03-S	Molykote G-n	Contains Outer Air filter, oil,oil filter, spark plugs, fuel filter

Common Attachment Wear Parts

Attachment	Component	Replacement Part Number
Fine Finish Broom	Brushes (3)	10-10203
Rigid Dragmat	Mat	10-90336
Coco Mat	Mat	10-90413
Pro Finisher	Screen	10-99140
VibraFlex	Small Pins (Silver)	10-10082
VibraFlex	Medium Pins (Gold)	10-10085
VibraFlex	Large Pins (Black)	10-10083
Profile Blade	Blades	10-90253
Mini Box	Cutting Edge - Solid (2)	10-30870
Mini Box	Cutting Edge - Serrated (2)	10-30871
Scarifiers	Tips (7)	10-40020
Stealth Blades	Blades (7)	10-99149
Multi-Function Rake	Teeth (Set)	10-99127
Tooth Bar	Teeth (27)	10-10506
Edger	Clean up Blade	10-99126
Clean up Tool	Clean up Blade	10-99126

Fluid List

Fluid	Capacity(Refill)	Spec
Gasoline	6 gallons	87 Octane E-10 or less
Engine Oil	1.7-2.0 qt	SAE 10W-30 OR 5W40
Hydraulic Oil	3-4 qt	5W-40 Full Synthetic

Electrical System

Item	Location	Rating	Operation
Main System Fuse	Top of Battery	20 Amp ATC	Powers Entire Machine
Laser Power Fuse(optional)	Top of Battery	20 Amp ATC	Powers Laser System
USB Plug Fuse	Under Left Side of Dash	7.5 Amp ATC	Powers USB Port in Dash
Fan Relay	Under Left Side of Dash	20 Amp "Bosch" Style	Controls Hydraulic Cooling Fan
Light Relay	Under Right Side of Dash	20 Amp "Bosch" Style	Controls Low Hydraulic Oil Light

abdiFORCE®